



## Series 300

The direct operated solenoid valve is the interface between pneumatic and electronic. In fact, it is actuated by an electrical signal and in turn gives a pneumatic signal directly available for small users or for actuating bigger pneumatic distributors.

A wide range of valves are needed for satisfying various applications. For this need we have available miniature components with very low volume and electrical impute as well as solenoid valves with large flow rate and power for heavy duty operations. These solenoid valves are usually 3/2, normally closed or normally open, but there are available the 2/2, closed or open, for vacuum and others.

Note that the direct operated valves can only be used with bases, individual or multiple with M5 or G 1/8" thread or with connections.

Some PNEUMAX solenoid valves are  homologated valid for USA and Canada (file n. VAIU2.E206325, VAIU8.E206325). For more details, refer to the coding, in the following pages.

The 10mm and 15mm solenoid valves are certified by UL in compliance with both Canadian and USA safety requirements as recognized component and included in the **UL file E206325** and bear the "UL Recognized Component" marking.

The 10mm and 15mm solenoid valves, since they are devices for "class 2 circuits", according with UL standard UL 429/CSA C22.2 N°139, are not considered dangerous for electric shock or fire and thus a **UL certification is not required for cables and connectors.**

Some solenoid valves, since they are devices for "class 2 circuits", according with UL standard UL 429/CSA C22.2 N°139, are not considered dangerous for electric shock or fire and thus a **UL certification is not required for cables and connectors.**

### Use and maintenance

Maintenance is normally not required for these components therefore the spare parts list is not provided.

Their construction complexity and low cost do not make repair economically viable. It's easier and more economic to replace the complete valve in case of malfunction.

For proper lubrication use only hydraulic oil class H such as Castrol type MAGNA GC 32.

This series of directly operated valves is characterized by its reduced dimensions. They are designed to be mounted individually or on manifold. The high operating speed and high flow rate in consideration of the reduced dimensions, in combination with the high compatibility of the material used to manufacture them ensure a high variety of possible application fields.

All valves have manual override as standard and are available in 3/2 configuration N.O. and N.C. as well as 2/2 N.C. both 12 or 24 V DC or AC. Electrical connection can be via co moulded cables or via connector, in this configuration a LED indicates the coil status. Ensure that the fixing screws are tightened with 0.15 Nm maximum.

1  
AIR DISTRIBUTION

**Functional schematics for standard version**

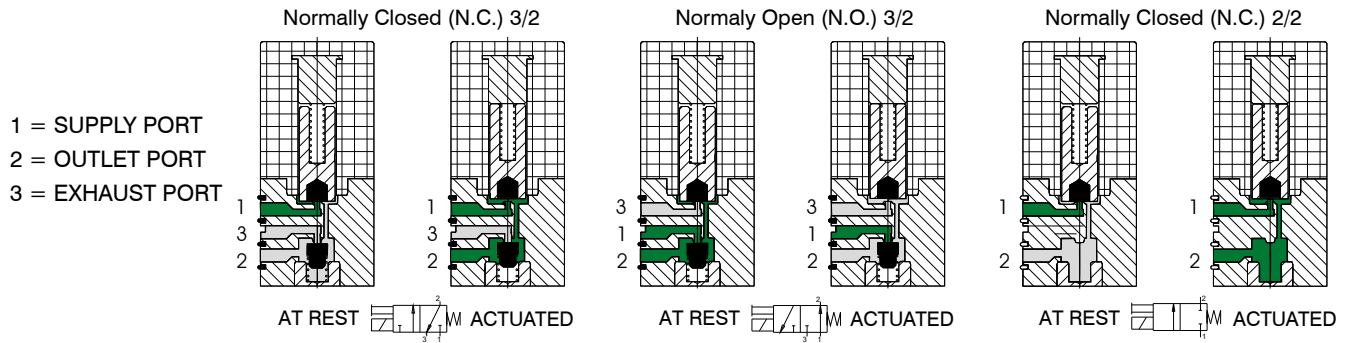

**Construction characteristics**

**Electrical part**

Miniature solenoid consisting of a coil made of copper wire of different diameters depending on voltage, isolated according to "F" class standard, with injection-moulded nylon-glass application. All parts forming the cladding, the electrical connections and the pole pieces are protected against corrosion.

**Mechanical part**

Stainless steel 430F armatures FPM poppets body in thermoplastic material and manual override and plug in nickel plated brass. Valves must be mounted on single or multiple manifold to be used.

**Technical characteristics**

		Standard version
<b>Pneumatic</b>	Working pressure	0 ... 7 bar
	Orifice size	0,7 mm
	Temperature	-5° ... +50°C
	Flow rate at 6 bar with Δp=1 bar	14 NI/min
	Exhaust flow rate	22 NI/min
	Life expectancy, number of cycles per minute	50 million
	Compressed air, purity class according to ISO 8573-1:2010	5:4:4
<b>Electric</b>	Voltages	12 ... 24 Volt D.C.
	Power	1,3 Watt
	Voltage tolerance	-5% ... +10%
	Response time when energized *	8 ms
	Response time when de-energized *	10 ms
	Copper wire isolation class	F (155°C)
	Protection degree	IP65 (with cables) IP40 (with connectors) IP00 (with Faston)

(\*) \*Response time of pneumatic directional control valves or moving parts, logic devices were measured in accordance to ISO 12238:2001, Pneumatic fluid power - Directional control valves - Measurement of shifting time\*

10 mm Standard miniature solenoid ordering codes

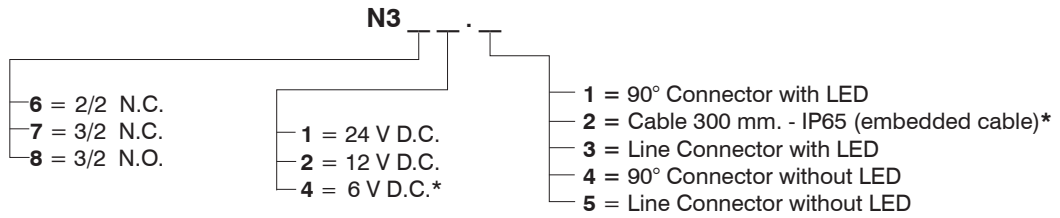

\* = The CE directive does not apply to these versions

Miniature solenoid valve with cable

Weight 12 g

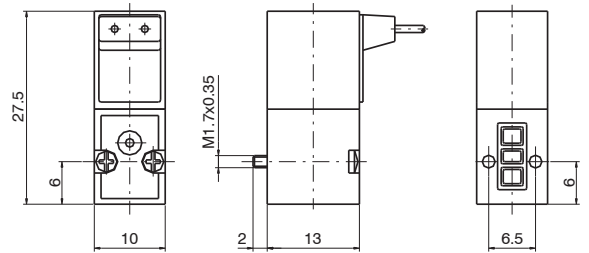

Miniature solenoid valve with 90° connector

Weight 12 g

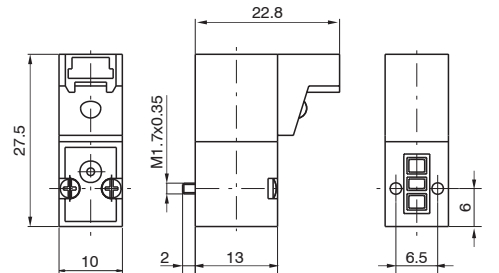

Miniature solenoid valve with line connector

Weight 12 g

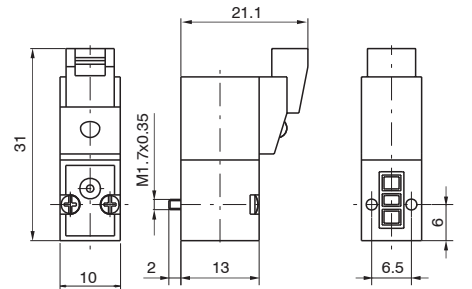

Connector

Ordering codes

- 371 .
  - 300 : Cable L = 300 mm
  - 600 : Cable L = 600 mm
  - 1000 : Cable L = 1000 mm

Weight 3 g

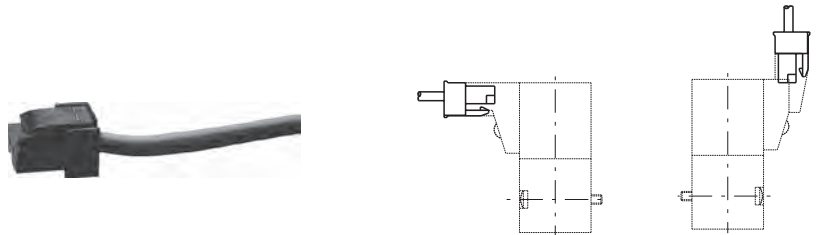

Closing plate

Ordering codes

395.00

Weight 5 g

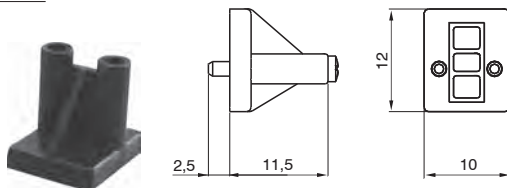

Interfaces dimensions

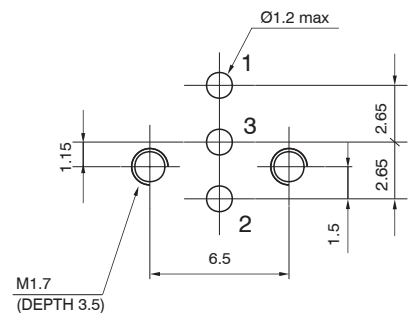

1  
AIR DISTRIBUTION

**10 mm - ISO 15218-2003 miniature solenoid ordering codes**

The versions are not contemplated by the CE directive

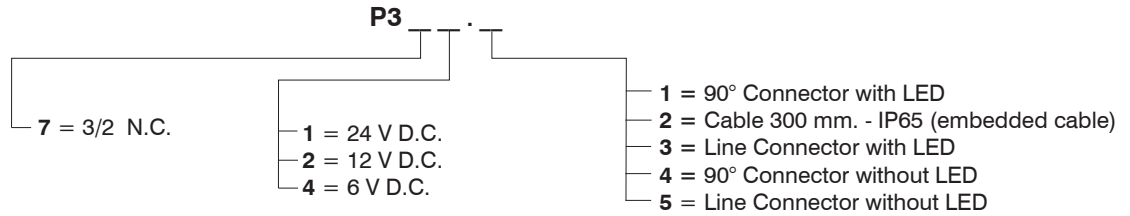

**Miniature solenoid valve with cable**



Weight 12 g

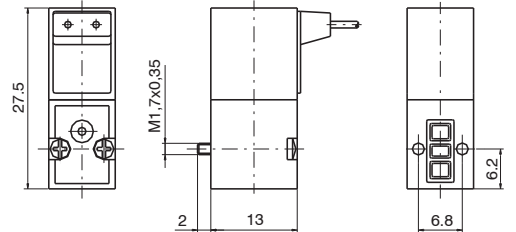

**Miniature solenoid valve with 90° connector**



Weight 12 g

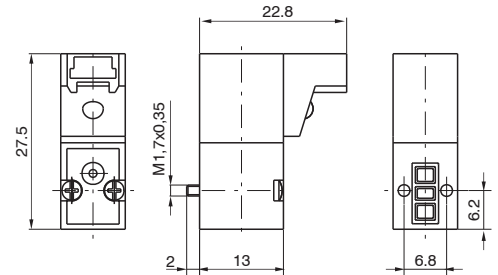

**Miniature solenoid valve with line connector**



Weight 12 g

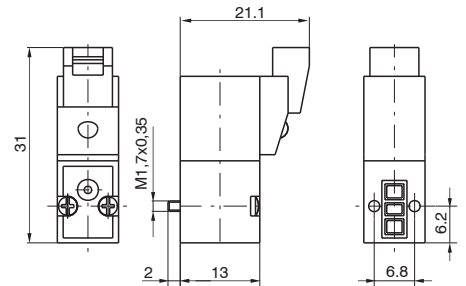

**Connector**

Ordering codes

- 371 .**
- 300 : Cable L = 300 mm
  - 600 : Cable L = 600 mm
  - 1000 : Cable L = 1000 mm

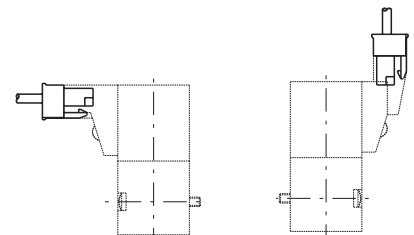

Weight 3 g

**Interfaces dimensions 10 mm - ISO 15218**

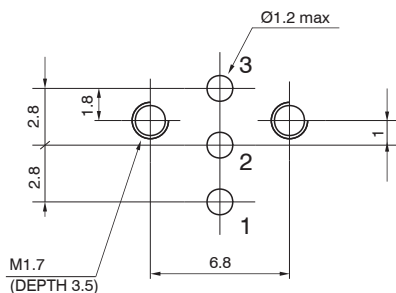

**Standard version  
Individual base**

Ordering code

**395.01**

Weight 10 g

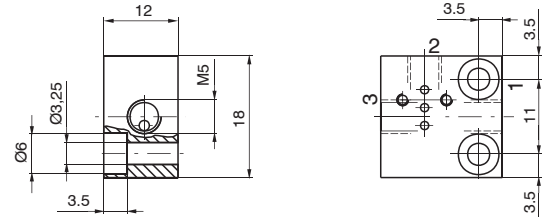

**Standard version  
multiple bases**

Ordering code

**395 .**

No. Positions

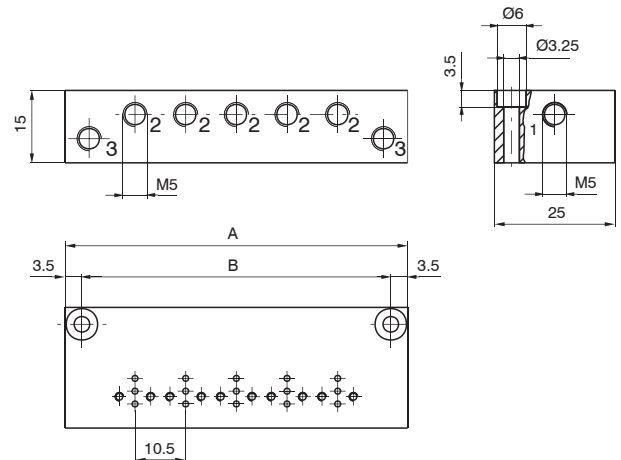

No. Positions	02	03	04	05	06	07	08	09	10
A	39.5	50	60.5	71	81.5	92	102.5	113	123.5
B	32.5	43	53.5	64	74.5	85	95.5	106	116.5
Weight (g)	43	54	65	76	87	98	109	120	131

**Individual base for  
ISO 15218-2003 version**

Ordering code

**P395.01**

Weight 10 g

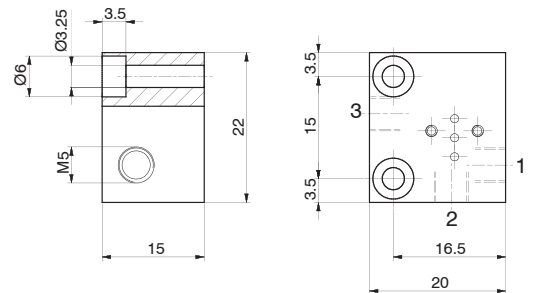

**Multiple base for  
ISO 15218-2003 version**

Ordering code

**P395 .**

No. Positions

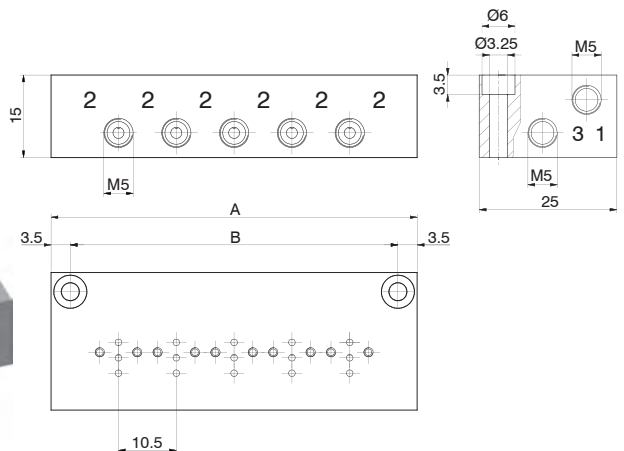

No. Positions	02	03	04	05	06	07	08	09	10
A	35	45.5	56	66.5	77	87.5	98	108.5	119
B	28	38.5	49	59.5	70	80.5	91	101.5	112
Weight (g)	43	54	65	76	87	98	109	120	131



This direct operated solenoid valve has minimum overall dimensions (15 mm wide). Its construction method is same as 10 mm valve, of course.

It is suitable to be single or gang mounted or as electro-operator for larger air flow distributors.

Can be utilized with compressed air and other fluids compatible with material used to build the solenoid valve.

The available versions, all equipped with manual override, are 3 ways, normally closed and normally open with DC and AC 50/60 Hz.

It's possible to install the N.O. valve on N.C. interface by using the registered reverse system included in the valve body.

The electrical connection is made with cables (300 mm.), FASTON or with connector.

This type of miniature solenoid valve is interchangeable with most of the same products available on the market.

Coil can also be positioned at 180° to get the electrical connection located on the opposite side than override.

Make sure that the fastening screws are tightened with maximum torque of 0,75 Nm.

1 AIR DISTRIBUTION

**Functional schematics**

- 1 = SUPPLY PORT
- 2 = OUTLET PORT
- 3 = EXHAUST PORT

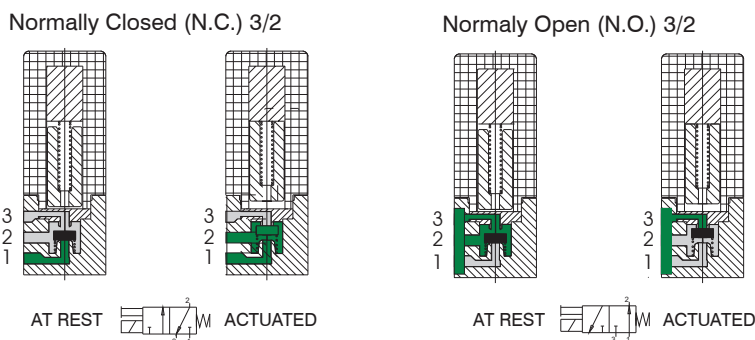

**Construction characteristics**

**Electrical part**

Miniature solenoid consisting of a coil made of copper wire of different diameters depending on voltage, isolated according to "F" class standard, with injection-moulded nylon-glass application. All parts forming the cladding, the electrical connections and the pole pieces are protected against corrosion.

**Mechanical part**

AISI 430F cores, AISI 302 return springs, FPM poppets, thermoplastic polyester body.

**Technical characteristics**

**Pneumatics**

Orifice size	0,8 mm	1,1 mm	1,5 mm (only D.C.)
Flow rate at 6 bar with $\Delta p=1$ bar	20 NI/min	30 NI/min	50 NI/min
Working pressure for N.C.	0 ... 10 bar		0 ... 7 bar
Working pressure for N.O.	/	0 ... 8 bar	0 ... 5 bar
Temperature	-5° ... +50°C		
Max number of cycles per minute	50 million cycles (with standard working conditions)		
Compressed air, purity class according to ISO 8573-1:2010	5:4:4		

**Electrical**

Voltage D.C.	24 V DC	12-24 V DC	
Voltage A.C.	/	24-110-230 Volt 50/60 Hz	/
Power consumption D.C.	1 Watt	2,3 Watt	
Power consumption A.C.	/	2,8 VA (at starting) 2,5 VA (at speed)	/
Voltage tolerance	-5% ... +10%		
Response time*	10 ... 12 ms		
Isolating class	F (155°C)		
Protection degree	IP65 (with cables) IP40 (with connectors) IP00 (with faston)		

(\*) "Response time of pneumatic directional control valves or moving parts, logic devices were measured in accordance to ISO 12238:2001, Pneumatic fluid power - Directional control valves - Measurement of shifting time"

15 mm miniature solenoid ordering codes

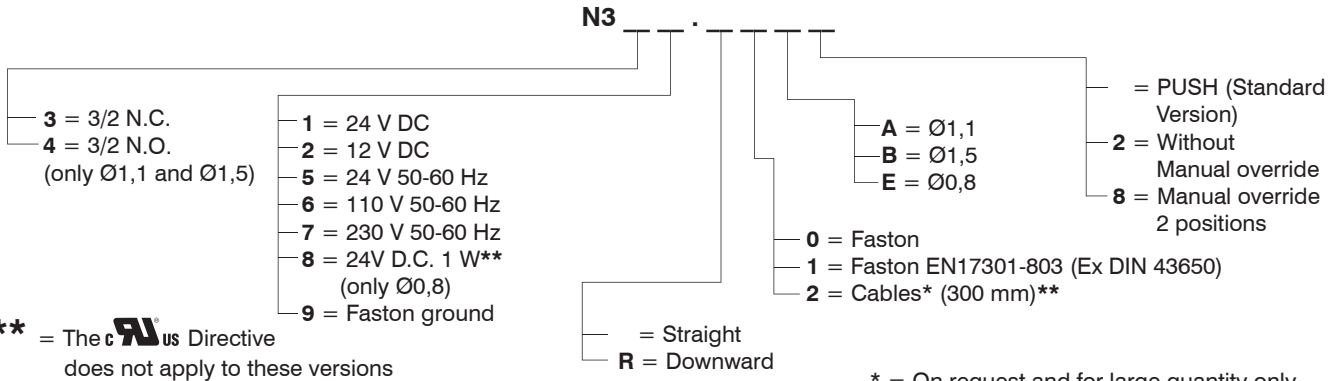

\*\* = The CE Directive does not apply to these versions

See previous page for available versions

\* = On request and for large quantity only (only 24 V D.C., 2.3 W)

With Faston



Weight 36 g

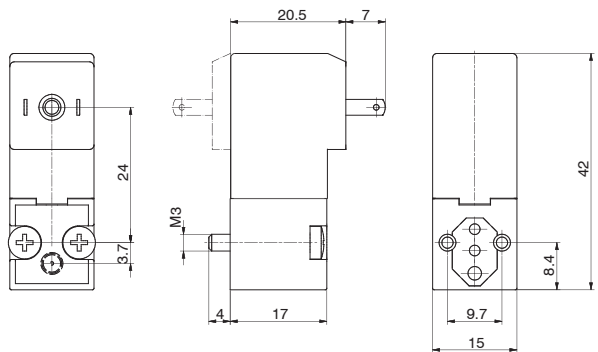

With Faston EN17301-803 (Ex DIN 43650)



Weight 36 g

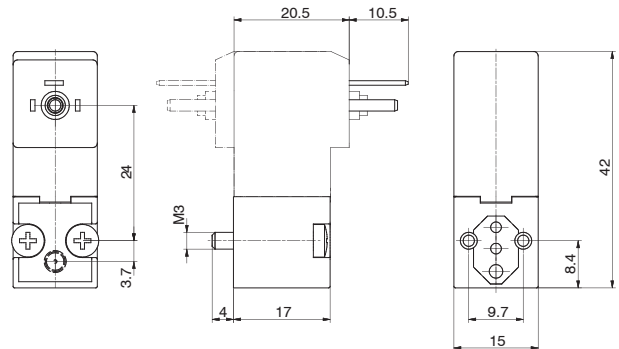

With Cables (300 mm)



Weight 38 g

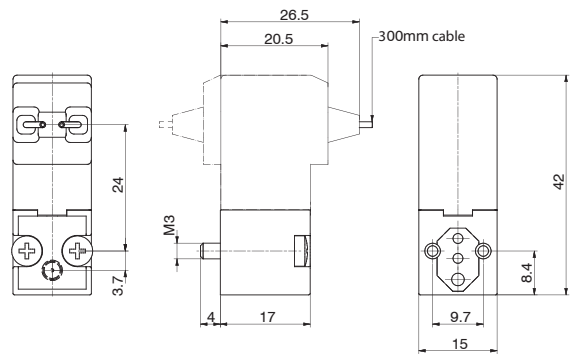

With Faston ground



Weight 38 g

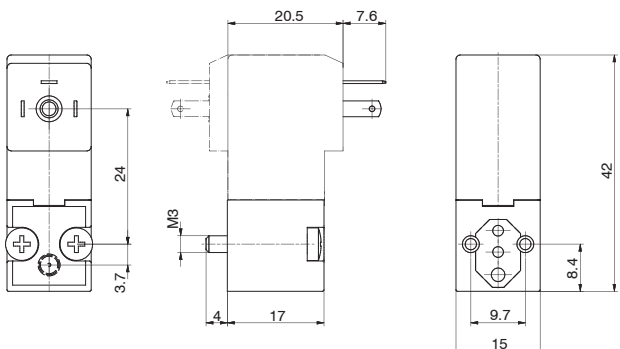

**Connector**

Ordering code

- 315.11.00** Standard
- 315.12.00** for faston EN17301-803 (Ex DIN 43650)
- 315.11.0 L** Led
  - 1 = 24 V D.C. / A.C.
  - 2 = 110 V 50/60 Hz
  - 3 = 230 V 50/60 Hz
- 315.12.0 L** for faston EN17301-803 (Ex DIN 43650) with LED
  - 1 = 24 V D.C. / A.C.
  - 2 = 110 V 50/60 Hz
  - 3 = 230 V 50/60 Hz

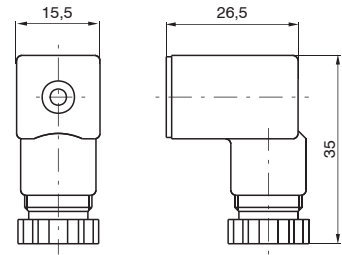

Weight 13 g

**Single use base**

Ordering code

**355.01**

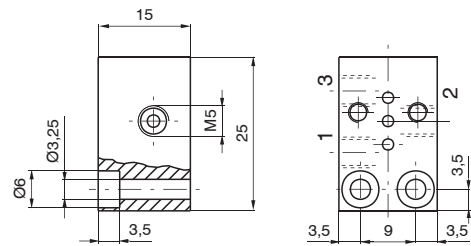

Weight 18 g

**Multiple bases**

Ordering code

A = Orifice M5

A = Pipe fitting Ø4

**355 .**

No. Positions

**354 .**

No. Positions

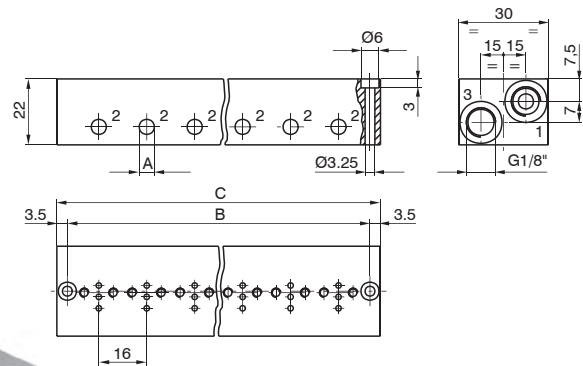

No. Positions	02	03	04	05	06	07	08	09	10
B	37	53	69	85	101	117	133	149	165
C	44	60	76	92	108	124	140	156	172
Weight (g)	66	92	116	141	165	190	216	242	266

**Closing plate**

Ordering code

**355.00**



Weight 6 g

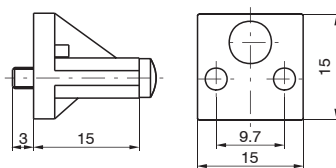

**Interface dimensions**

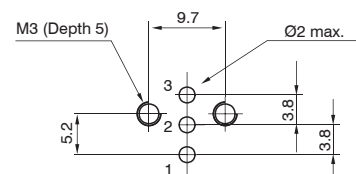

### 15mm Solenoid valves Manifold with electric multipoint connection

Also for this 15mm solenoid valves series we have realized the possibility of the assembling on the base with multipoint connection, this for making faster the connection and the harness of them.

Realized from a shaped outline, it results compact because it uses a relevant multipoint connection available only with a 37 poles connector from 10 to 32 solenoid valves (with steps of 2), available in line or at 90° and IP40 protection. On the base it is possible to put some threaded cartridges with push-in fittings for Ø3 – Ø3,17 Ø4 tube or M5 threaded.

The application field of these new configurations is the standard of 3/2 valves, where it is needed to realize groups or Manifolds provided with integrated electric connection to make easier and faster the connection and the harness of them (control of single acting cylinders with small dimensions, pilot system of valves with bigger dimensions etc..).

#### Constructive characteristics:

##### Constructive principle:

From 10 up to 32 solenoid valves (with steps of 2)

Extremely compact solution

IP40 protection (without visualisation led)

Possibility of having different working connections (Ø3, Ø3,17, Ø4 tubes, M5)

The new coding key requires the use of the same type of solenoid valves (there aren't codes for groups with a mixed configuration).

#### Overall dimensions

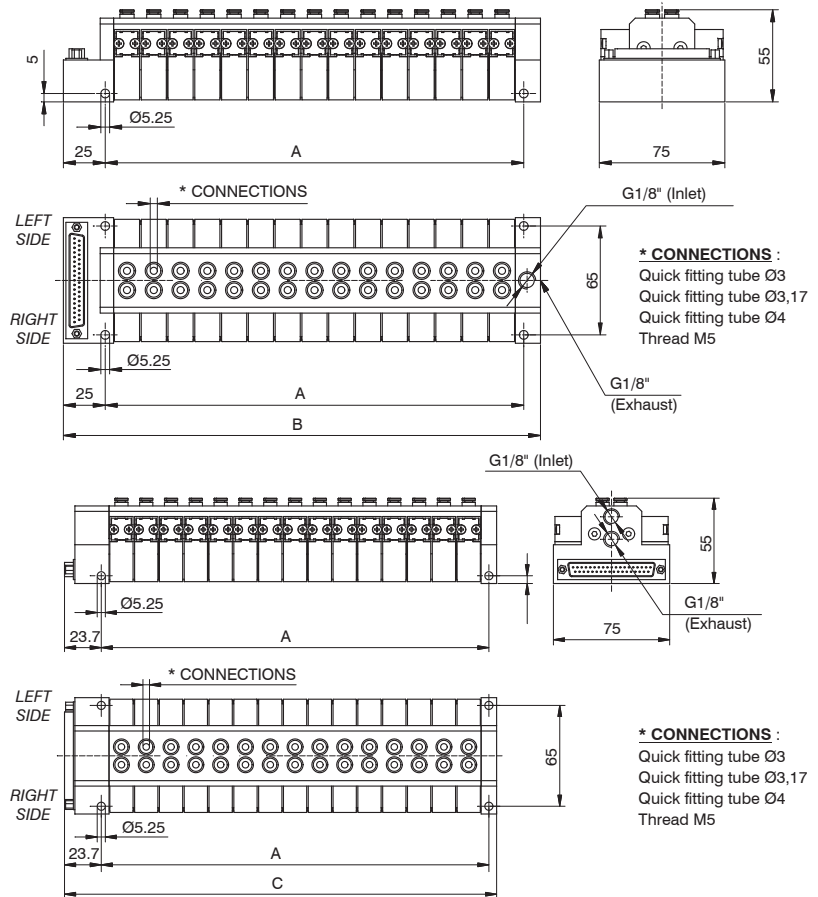
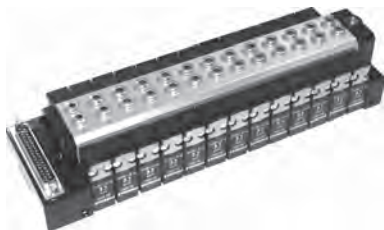

No. Positions	A	B	C
10	90	125	118,7
12	106	141	134,7
14	122	157	150,7
16	138	173	166,7
18	154	189	182,7
20	170	205	198,7
22	186	221	214,7
24	202	237	230,7
26	218	253	246,7
28	234	269	262,7
30	250	285	278,7
32	266	301	294,7

#### SUB-D 37 POLES CONNECTORS

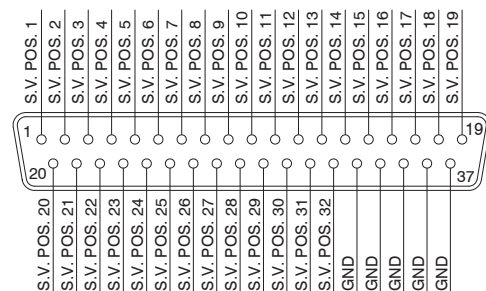

**Overall dimensions**  
**Manifold with CANopen® node**

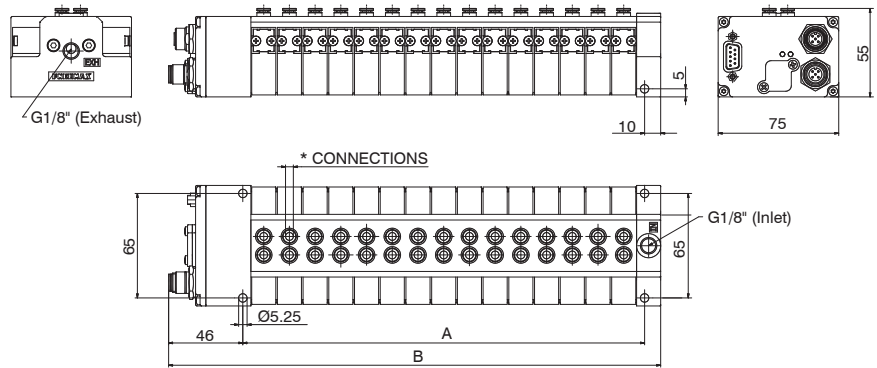

No. positions	A	B
10	90	146
12	106	162
14	122	178
16	138	194
18	154	210
20	170	226
22	186	242
24	202	258
26	218	274
28	234	290
30	250	306
32	266	322

1 AIR DISTRIBUTION

**Manifold layout configuration**

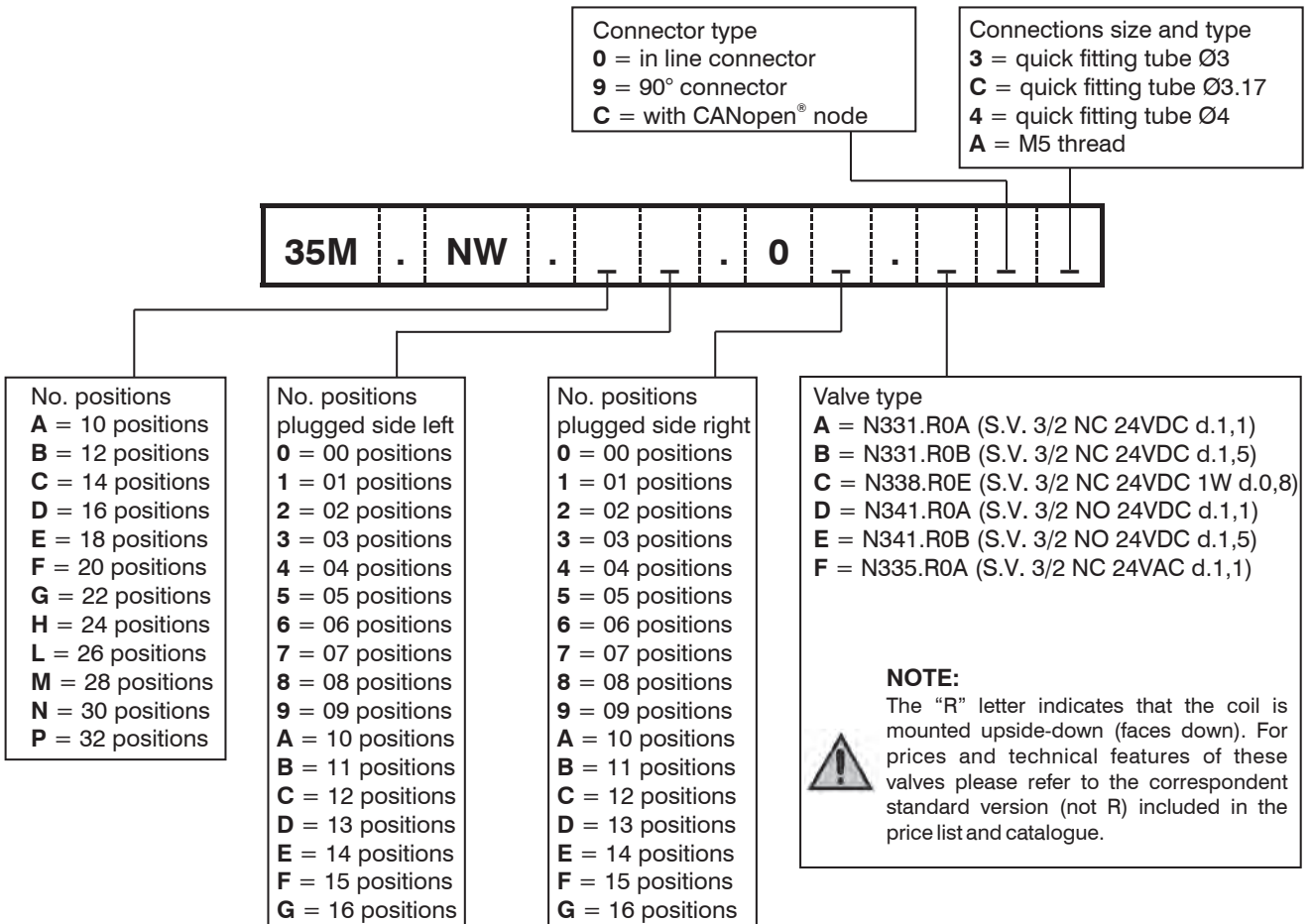

**Overall dimensions**

**Manifold with Optyma-F serial system (slave + input modules)**

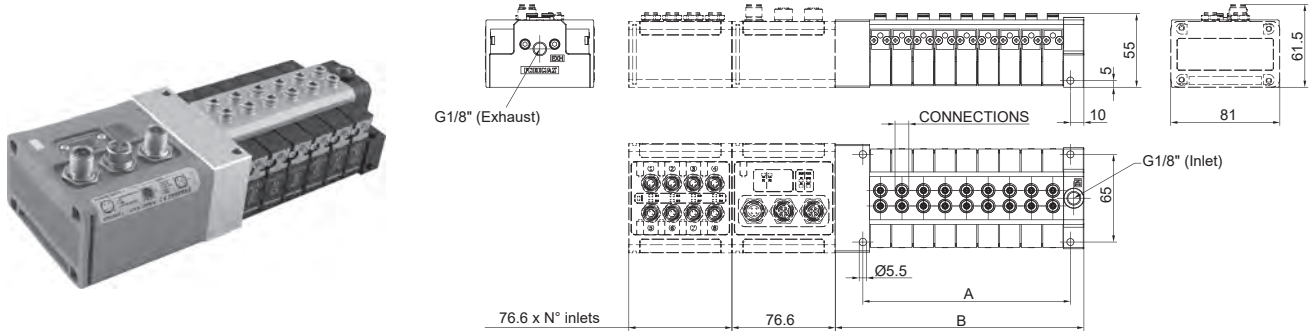

No. positions	A	B
10	90	120,50
12	106	136,50
14	122	152,50
16	138	168,50
18	154	184,50
20	170	200,50
22	186	216,50
24	202	232,50
26	218	248,50
28	234	264,50
30	250	280,50
32	266	296,50

**Manifold layout configuration with Optyma-F serial system (slave + input modules)**

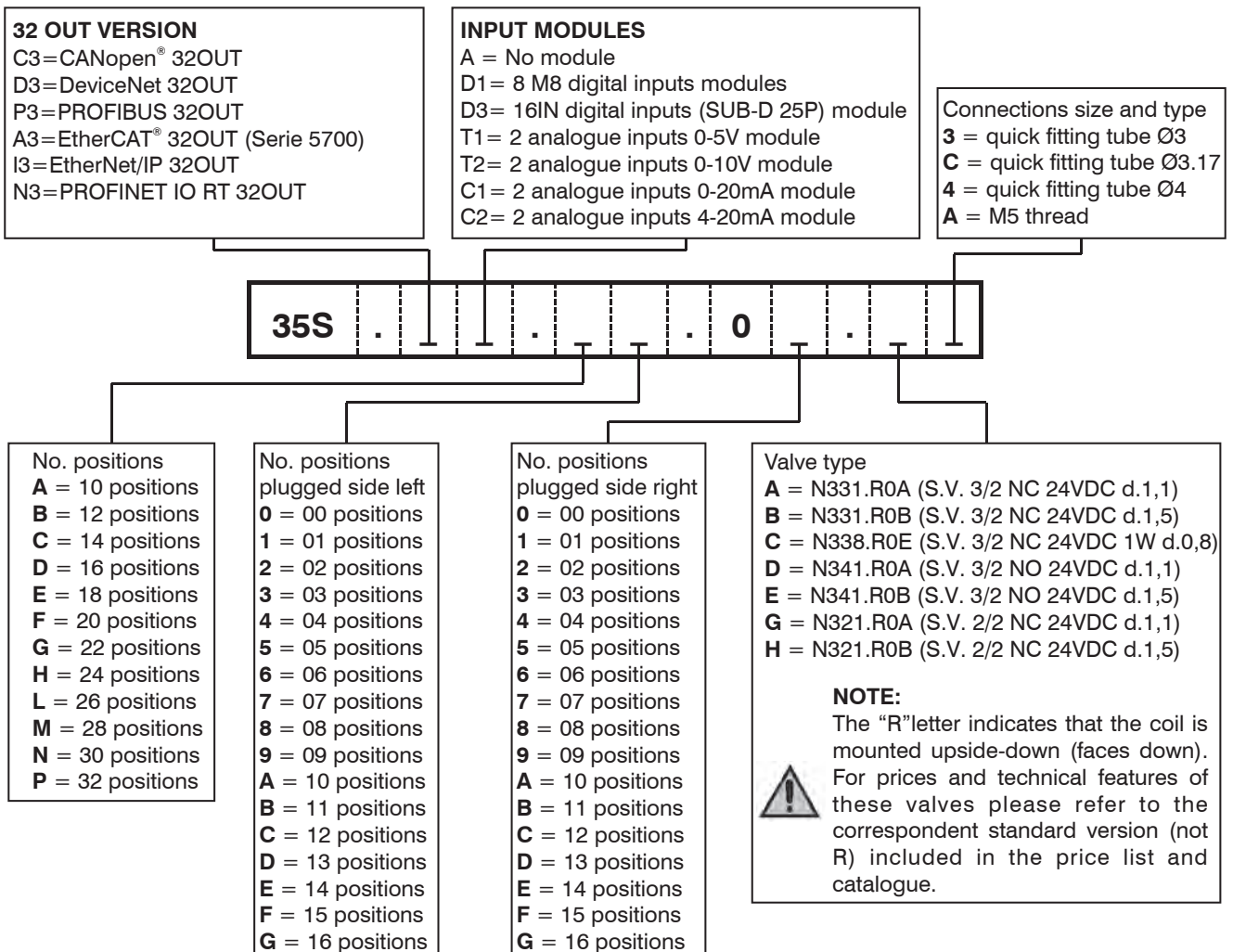

**Functional schematics**

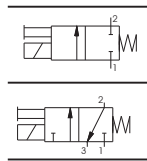

- 1 = INLET PORT
- 2 = OUTLET PORT
- 3 = EXHAUST PORT  
(Plugged if 2/2)

**Normally Closed (N.C.) 3/2 or 2/2**

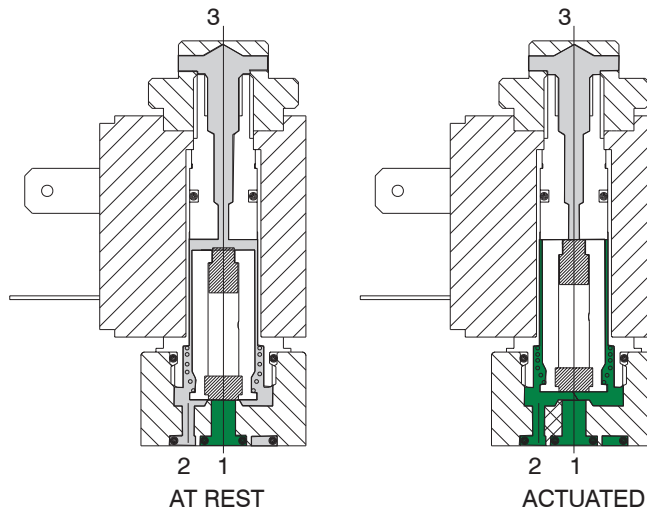

**Normally Open (N.O.) 3/2 or 2/2**

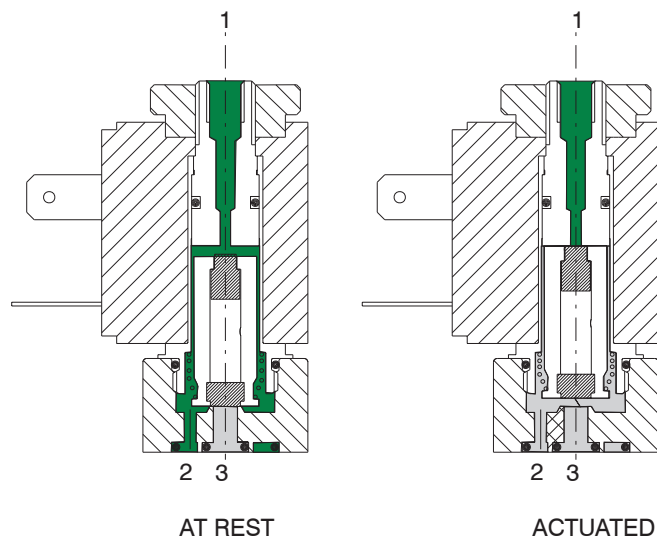

**Construction characteristics**

**Electrical parts:** Solenoids: the solenoid consist of coils having different diameter copper wire windings insulated according standards "H"; they are encased in a nylon-glass compound. All parts are corrosion resistant.

**Mechanical parts:** Nickel plated brass tube nitrile viton seals stainless steel plunger (AISI 430F), stainless steel adjusted springs, viton poppet seals, tropicalized zinc alloy interface plate, nickered brass manual override, nickel steel coil lock nut, zinc steel mounting screw. To be usable, the solenoids and microsolenoids have to be attached either to a base or directly to the distributor's operators by means of connectors M5 or G 1/8". These solenoids are available in all voltages and frequencies used in the world. The following are the technical characteristics of the solenoid.

1 AIR DISTRIBUTION



## Technical characteristics

<b>Pneumatic</b>	Working pressure	0 ... 10 bar	
	Orifice size	1,3 mm	(0,9 mm for 2 W)
	Maximum fluid temperature	50°C	
	Maximum ambient temperature	-40°C ... +50°C	
	Maximum flow rate at 6 bar with $\Delta p$ 1 bar	53 NI/min	(20NI/min. for 2 W)
	Cycles/minute	700	
	Fluids	Air-vacuum-inert gases	
	Lubrication	non required	
Life	45 to 50 million cycles		
<b>Electrical</b>	Power consumption holding - D.C	5 W	(2.5 W) low consumption
	Power consumption holding - A.C	9 VA	(6 VA) low consumption
	Operating voltage tolerance	$\pm 10\%$	
	Response time opening *	8 ms	
	Response time closing *	6 ms	
	Insulation of the copper wire	H	
	Insulation of the coil	F	
	Connector protection	IP 65	
Cable protection	DIN 43650 INDUSTRIAL FORM		

(\*) "Shifting time of pneumatic directional control valves or moving parts, logic devices were measured in accordance to ISO 12238:2001, Pneumatic fluid power - Directional control valves - Measurement of shifting time"

## Maintenance and replacement parts

Maintenance practices for these valves are similar to those already detailed for other products- replacement of the plunger or poppet is not advisable since the new replacement would not provide the best fit with the rest of the already used valve. Special care should be taken that no dirt is accumulated between the working surface of fixed core and the plunger which would result in vibrations and overheating of the solenoid. In the case of microsolenoid it must be assured that the alternate current coil is not charged when the mechanical part is not mounted to avoid destruction of the coil. The electrical connections have to be perfect, especially where low currents are used (12-24V). Oxidation of contacts between the connector and the coil can lead to intermittent malfunctions which are difficult to trace. Oxidation of contacts due to humidity or corrosive atmosphere are one of the most common causes of false alarms. Clean the contacts with appropriate spray.

**Mechanical actuator for miniature solenoid valve**

Ordering code

- M 2** Normally Closed (N.C.)
- M 2P** Normally Closed (N.C.) threaded lock nut
- M 2/9** Normally Closed (N.C.) 2 W 24 VDC

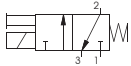

Weight 51 g

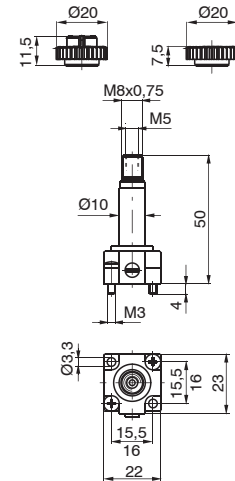

- M 2/1** Normally Open (N.O.) air feeding through fix flunger

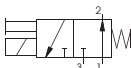

Weight 48 g

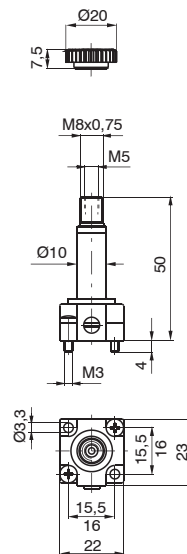

- Normally Open (N.O.) air feeding through base

**MM 7**

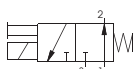

Weight 46 g

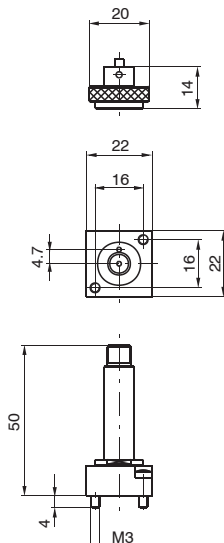

Ordering code	Available voltages Coil	
N.O.		
<b>MB10/1</b>	24 D.C. (8 Watt)	Direct current
<b>MB17/1</b>	24/50	Alternating current 50 Hz
<b>MB21/1</b>	48/50	
<b>MB22/1</b>	110/50	
<b>MB24/1</b>	230/50	
<b>MB37/1</b>	24/60	Alternating current 60 Hz
<b>MB39/1</b>	110/60	
<b>MB41/1</b>	230/60	
<b>MB56/1</b>	24/50-60	Alternating current 50/60 Hz
<b>MB57/1</b>	110/50-60	
<b>MB58/1</b>	230/50-60	