

Electric pilot CNOMO (coil not included)

Mechanics with base for solenoid to be used where an electric pilot system is required. May be used on all sizes and is standardized as an interface on the distributor.

The base is fitted with a manual control which is pulse actuated, without check, or with two stable positions, actuated by means of a screwdriver (pressing down and turning clockwise by 90°). Two different types of solenoids can be mounted on the stem, one in conformity with ISO standard size 30x38 and ISO 4400 (DIN 43650) electrical connection, and a compact one size 22x27, having the same performance but at lower price. The technical characteristics of the latter are described in the catalogue, series 300, and refer to MB solenoids. The base is fitted with screws (M4x30) for fastening to the distributor.

Ordering code



P = Manual 1 position
R = Manual 2 positions

3 = Mechanics CNOMO
4 = 2 W Mechanics CNOMO

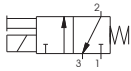

Weight 49 g

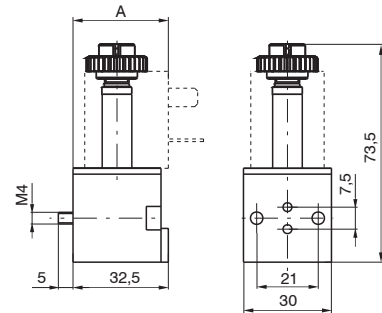

A = 33 (with MB solenoid)
A = 38 (with MC solenoid)

General characteristics

Structural	Body	Thermoplastic polyester	
	Stem	Nickel-plated brass	
	Cores	AISI 430F stainless steel	
	Springs	AISI 302 stainless steel	
	Shutters	FPM	
	Other seals	NBR	
	Manual control	Nickel-plated brass	
	Pneumatic	Fluid	Air, Neutral gases
Working pressure		0 ... 10 bar	
Fluid ambient temperature		-5°C ... +50°C	
Flow rate at 6 bar with Δp 1 bar		53 NI/min	(20 NI/min for 2 W)
Nominal flow cross section		1,3 mm	(0,9 mm for 2 W)
Electric	Power consumption (inrush) - A.C.	13 VA	
	Power consumption holding - D.C.	4 W	(2 W)
	Power consumption holding - A.C.	8,5 VA	
	Operating voltage tolerance	$\pm 10\%$	
	Response time opening *	13 ms	
	Response time closing *	5 ms	
	Insulation of the copper wire	H	
	Insulation of the coil	F	
	Connector protection	IP 65	
Cable protection	DIN 43650 "A" FORM		

(*) "Shifting time of pneumatic directional control valves or moving parts, logic devices were measured in accordance to ISO 12238:2001, Pneumatic fluid power - Directional control valves - Measurement of shifting time"

Coil

Ordering code	Available voltages
	Coil
MC5	24 D.C.
MC9	24 D.C. (2 Watt)
MC56	24/50-60 Hz
MC57	110/50-60 Hz
MC58	230/50-60 Hz



Weight 110 g

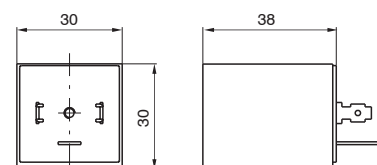

Functional schematic

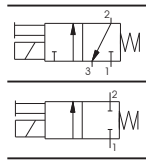

- 1 = INLET PORT
- 2 = OUTLET PORT
- 3 = EXHAUST PORT
(Plugged if 2/2)

Normally Closed (N.C.) 3/2 or 2/2

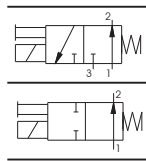
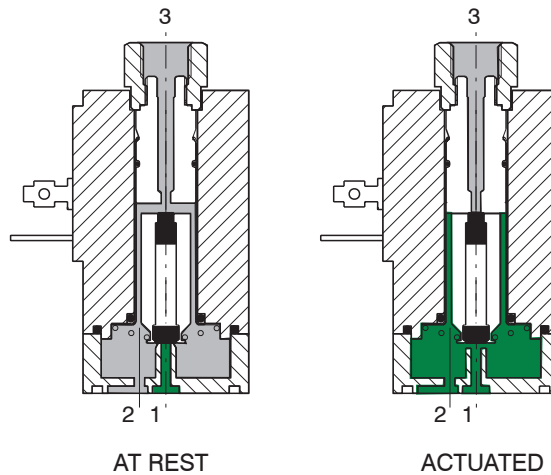

Normally Open (N.O.) 3/2 or 2/2

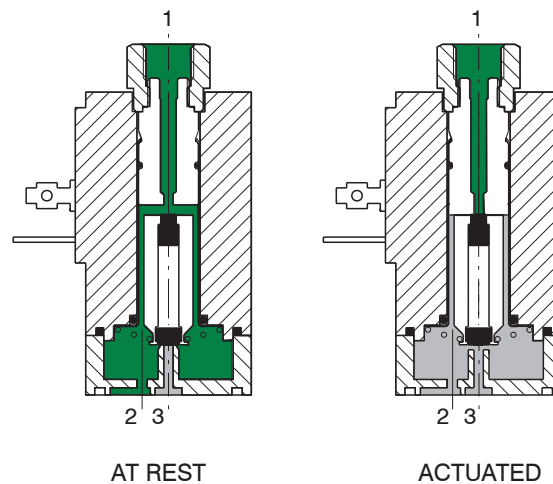

Construction characteristics

Electrical parts:

Solenoids: the solenoid consists of coils having different diameter copper wire windings insulated according standards "H"; they are encased in a nylon-glass compound. All parts are corrosion resistant.

Mechanical parts:

Stainless steel tube and plunger (AISI 430F), stainless steel adjusted springs, viton poppet seals, tropicalized zinc alloy interface plate, nitrile (NBR) seal nicked brass manual override, nickel steel coil lock nut, zinc steel mounting screws. To be usable, the solenoids have to be attached either to a base or directly to the distributor's operators by means of connectors G 1/8". Electrical connectors are standard. These solenoid are available in all voltages and frequencies used in the world. The following are the technical characteristics of the solenoid.

1 AIR DISTRIBUTION



Technical characteristics

Pneumatic	Working pressure	0 ... 10 bar
	Orifice size	1,8 mm
	Maximum fluid temperature	50°C
	Maximum ambient temperature	50°C
	Maximum flow rate at 6 bar with $\Delta p = 1$	80 NI/min
	Cycles/minute	700
	Fluids	Air-Vacuum-Inert gases
	Lubrication	Not required
	Life	40 to 50 millions
Electric	Power consumption (inrush) - D.C.	-
	Power consumption (inrush) - A.C.	19,5 VA
	Power consumption holding - D.C.	8,2 W
	Power consumption holding - A.C.	9 VA
	Operating voltage tolerance	$\pm 10\%$
	Response time opening *	15 ms
	Response time closing *	30 ms
	Insulation of the copper wire	H
	Insulation of the coil	F
	Connector protection	IP 65
	Cable protection	DIN 43650 "A" FORM

(*) "Shifting time of pneumatic directional control valves or moving parts, logic devices were measured in accordance to ISO 12238:2001, Pneumatic fluid power - Directional control valves - Measurement of shifting time"

Maintenance and replacement parts

Maintenance practices for these valves are similar to those already detailed for other products - replacement of the plunger or poppet is not advisable since the new replacement would not provide the best fit with the rest of the already used valve.

Special care should be taken that no dirt is accumulated between the working surface of fixed cores 3 and the plunger 2 which would result in vibrations and overheating of the solenoid. In the case of microsolenoid it must be assured that the alternate current coil is not charged when the mechanical part is not mounted to avoid destruction of the coil.

The electrical connections have to be perfect, especially where low currents are used (12-24 V). Oxidation of contacts between the connector and the coil can lead to intermittent malfunctions which are difficult to trace. Oxidation of contacts due to humidity or corrosive atmosphere are one of the most common causes of false alarms. Clean the contacts with appropriate spray.