

Series 514/N

The **514/N** Solenoid valves, are 2 stage valves actuated electro-pneumatically. A series 300 directly operated solenoid valve actuates pneumatically the principal power distributor.

Everything is well integrated in a practical configuration that also permits applications where there is limited space. Used primarily to operate rotary actuators and wherever there is a **NAMUR** standard installation plan.

The pilot air is normally taken from the inlet port (autofeed) and the only actuating signal is electric.

The range of the solenoid valves, as far as dimensions and mechanical construction, is similar to series 200. We have therefore solenoid valves G 1/4" with identical pneumatic characteristics that are, however, actuated electrically. They have a balanced spool, insensitive to presence or absence of pressure. They are constructed in 3 and 5 way with 1 solenoid (monostable) or 2 solenoids (bistable).

“NAMUR” interface dimensions:
according to standard (VDI/VDE 3847 July 2003)

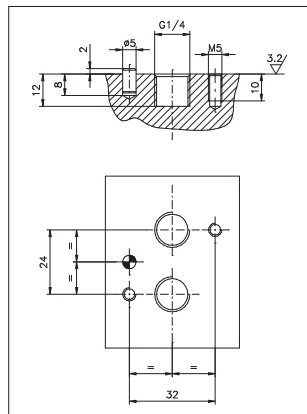

Construction characteristics

Body	Aluminium
Spacers	Technopolymer
Seals	NBR
Springs	Spring steel
Operators	Aluminium
Spools	Nickel plated steel
Screws	Zinc plated steel

Use and maintenance

This valves have an average life of 15 million cycles depending on the application and air quality.

Filtered and lubricated air using specified lubricants will reduce the wear of the seals and ensures long and trouble free operation.

Please ensure that the valve is being used according with the manufacturers specification, such as air pressure and temperature.

The exhaust port of the distributor has to be protected in a dusty and dirty environment.

Repair kits including the spool complete with seals are available for overhauling the valves.

However, although this is a simple operation it should be carried out by a competent person.

ATTENTION: use hydraulic oil class H for lubrication such as CASTROL MAGNA SW32.

Solenoid-Spring

Coding: 514/N.①.0.1.M2

Operational characteristics

Fluid	Filtered air. No lubrication needed, if applied it shall be continuous
Max. working pressure (bar)	10
Temperature °C	-10 ... +50
Flow rate at 6 bar with Δp=1 (NI/min)	1030
Orifice size (mm)	7
Working ports size	G 1/4"

TYPE
① 32 = 3 ways, 2 positions
52 = 5 ways, 2 positions

3/2 ways

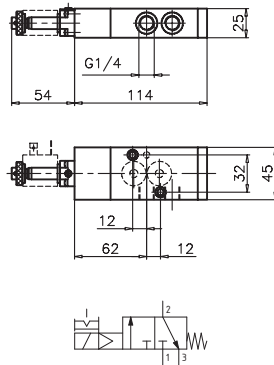

Weight 390 g
Minimum working pressure 2,5 bar

514/N.32.0.1.M2

5/2 ways

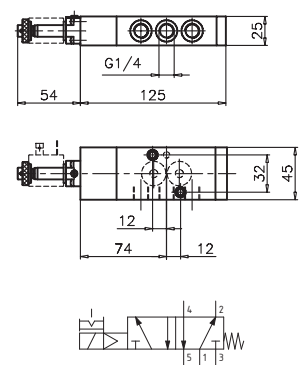

Weight 450 g
Minimum working pressure 2,5 bar

514/N.52.0.1.M2

Solenoid-Differential

Coding: 514/N.①.0.12.M2

Operational characteristics

Fluid	Filtered air. No lubrication needed, if applied it shall be continuous
Max. working pressure (bar)	10
Temperature °C	-10 ... +50
Flow rate at 6 bar with Δp=1 (NI/min)	1030
Orifice size (mm)	7
Working ports size	G 1/4"

TYPE
① 32 = 3 ways, 2 positions
52 = 5 ways, 2 positions

3/2 ways

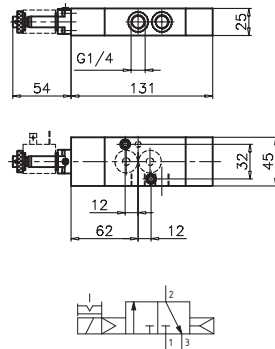

Weight 390 g
Minimum working pressure 2,5 bar

514/N.32.0.12.M2

5/2 ways

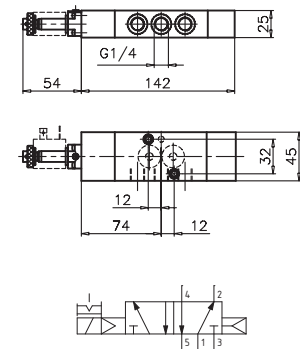

Weight 450 g
Minimum working pressure 2,5 bar

514/N.52.0.12.M2

Solenoid-Solenoid

Coding: 514/N.①.0.0.M2

Operational characteristics

Fluid	Filtered air. No lubrication needed, if applied it shall be continuous
Max. working pressure (bar)	10
Temperature °C	-10 ... +50
Flow rate at 6 bar with Δp=1 (NI/min)	1030
Orifice size (mm)	7
Working ports size	G 1/4"

TYPE
① 32 = 3 ways, 2 positions
52 = 5 ways, 2 positions

3/2 ways

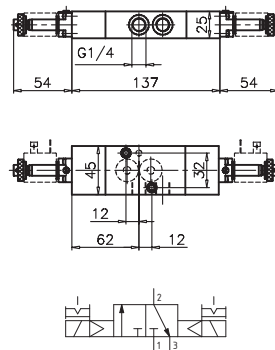

Weight 390 g
Minimum working pressure 2,5 bar

514/N.32.0.0.M2

5/2 ways

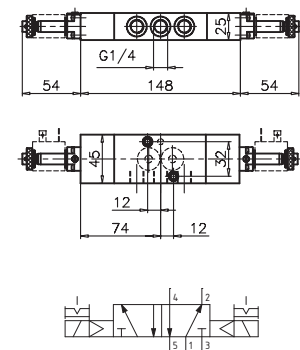

Weight 450 g
Minimum working pressure 2,5 bar

514/N.52.0.0.M2