



## Series 400

These are 2 stage valves actuated electro-pneumatically. A serie 300 directly operated solenoid valve actuates pneumatically the principal power distributor.

This integrated system allows configurations of systems requiring very little space.

The pilot air is normally taken from the inlet port (autofeed) and the only actuating signal is electric.

The range of the solenoid valves, as far as dimensions and mechanical construction, is similar to series 200.

We have therefore solenoid valves G 1/8", G 1/4", G 1/2" and G 1" with identical pneumatic characteristics that are, however, actuated electrically.

They have a balanced spool, insensitive to presence or absence of pressure. They are constructed in 3 and 5 way with 1 solenoid (monostable) or 2 solenoids (bistable) and also 5 ways 3 positions with closed centres, open centres and pressured centres.

It should be noted that the autofeed of the electric pilot requires always inlet through port 1 and if a 3 ways normally open configuration is desired, it is necessary to switch the operators.

Please note that while the microsolenoid can be mounted in any direction, standard solenoid requires mounting as indicated in the photographs and diagrams.

**The order codes pertain only to the solenoid valve with mechanical actuator "M2" or solenoid "S\*" already assembled.**

**M2 coils are not included and have to be ordered separately (see Series 300).**

**Coils for M2 and solenoids "S" homologated are available in RU (see Series 300).**

The solenoid valves **G1/8" (488)**, are supplied complete with coil (see Series 300) so that the tension has to be added to the solenoid valve code:

**M9** = coil 24 V D.C. (rating power 2 Watt)

**M11** = coil 24 V D.C. (rating power 3.8 watt)

**M56** = coil 24 V 50/60 Hz (rating power 9 VA)

**M57** = coil 110 V 50/60 Hz (rating power 9 VA)

**M58** = coil 230 V 50/60 Hz (rating power 9 VA)

"Shifting time of pneumatic directional control valves or moving parts, logic devices were measured in accordance to ISO 12238:2001"

### Construction characteristics

Body	Aluminium
Spacers	Technopolymer (aluminium for G1")
Seals	NBR Polyurethane compound for oil free applications (G 1/8", G 1/4" and G 1/2")
Springs	Stainless steel or spring steel
Operators	Aluminium Technopolymer for spring bottom plate G 1/8", G1/4", G 1/2" and aluminium for G 1"
Spools	Steel

### Use and maintenance

This valves have an average life of 15 million cycles depending on the application and air quality.

Filtered and lubricated air using specified lubricants will reduce the wear of the seals and ensures long and trouble free operation.

Please ensure that the valve is being used according with the manufacturers specification, such as air pressure and temperature.

The exhaust port of the distributor has to be protected in a dusty and dirty environment.

Repair kits including the spool complete with seals are available for overhauling the valves.

However, although this is a simple operation it should be carried out by a competent person.

**ATTENTION:** use hydraulic oil class H for lubrication such as CASTROL MAGNA SW32.

**Solenoid - Spring**

Coding: 468.1.0.1.M2

**Operational characteristics**

Fluid	Filtered air. No lubrication needed, if applied it shall be continuous
Max. working pressure (bar)	10
Temperature °C	-5 ... +50
Flow rate at 6 bar with Δp=1 (NI/min)	540
Orifice size (mm)	6
Working ports size	G 1/8"

TYPE	
1	32 = 3 ways, 2 positions 52 = 5 ways, 2 positions

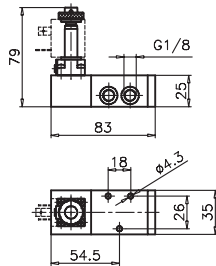
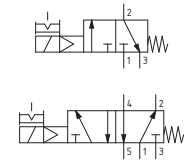

Weight 240 g  
Minimum working pressure 2,5 bar

468.32.0.1.M2

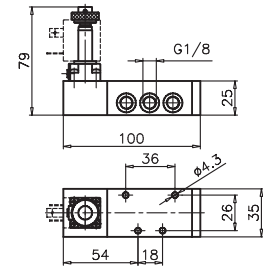

Weight 240 g  
Minimum working pressure 2,5 bar

468.52.0.1.M2

**Solenoid - Differential**

Coding: 468.1.0.12.M2

**Operational characteristics**

Fluid	Filtered air. No lubrication needed, if applied it shall be continuous
Max. working pressure (bar)	10
Temperature °C	-5 ... +50
Flow rate at 6 bar with Δp=1 (NI/min)	540
Orifice size (mm)	6
Working ports size	G 1/8"

TYPE	
1	32 = 3 ways, 2 positions 52 = 5 ways, 2 positions

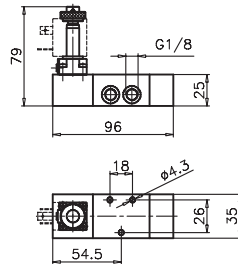
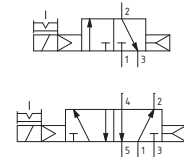

Weight 280 g  
Minimum working pressure 2,5 bar

468.32.0.12.M2

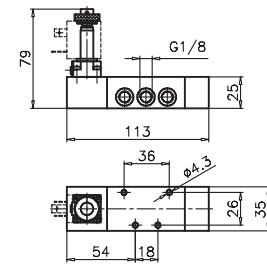

Weight 320 g  
Minimum working pressure 2,5 bar

468.52.0.12.M2

**Solenoid - Solenoid**

Coding: 468.1.0.0.M2

**Operational characteristics**

Fluid	Filtered air. No lubrication needed, if applied it shall be continuous
Max. working pressure (bar)	10
Temperature °C	-5 ... +50
Flow rate at 6 bar with Δp=1 (NI/min)	540
Orifice size (mm)	6
Working ports size	G 1/8"

TYPE	
1	32 = 3 ways, 2 positions 52 = 5 ways, 2 positions

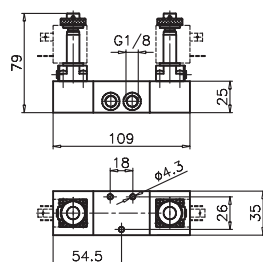
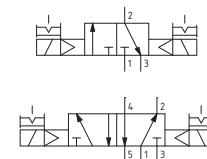

Weight 370 g  
Minimum working pressure 2 bar

468.32.0.0.M2

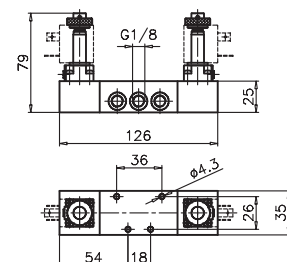

Weight 410 g  
Minimum working pressure 2 bar

468.52.0.0.M2

**Solenoid - Solenoid - 5/3**

Coding: 468.53.●.0.0.M2

Operational characteristics	
Fluid	Filtered air. No lubrication needed, if applied it shall be continuous
Max. working pressure (bar)	10
Temperature °C	-5 ... +50
Flow rate at 6 bar with Δp=1 (NI/min)	410
Orifice size (mm)	6
Working ports size	G 1/8"

FUNCTION	
●	31 = Closed centres
●	32 = Open centres
●	33 = Pressured centres

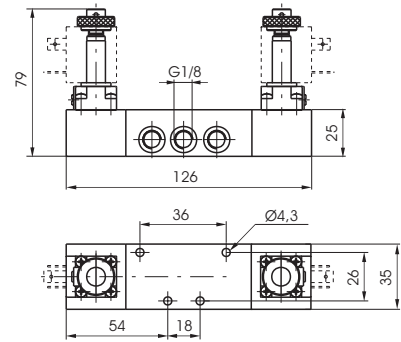
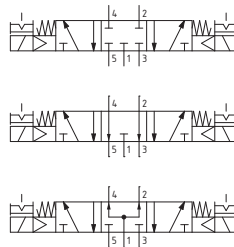

Weight 420 g  
Minimum working pressure 3 bar

**Solenoid - Spring**

Coding: 468/1.●.0.1.M2

Operational characteristics	
Fluid	Filtered air. No lubrication needed, if applied it shall be continuous
Max. working pressure (bar)	10
Temperature °C	-5 ... +50
Flow rate at 6 bar with Δp=1 (NI/min)	540
Orifice size (mm)	6
Working ports size	G 1/8"

TYPE	
●	32 = 3 ways, 2 positions
●	52 = 5 ways, 2 positions

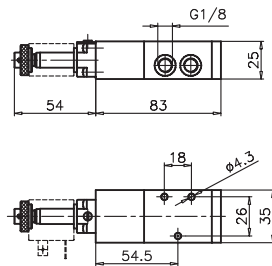
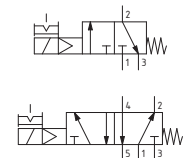

Weight 240 g  
Minimum working pressure 2,5 bar  
468/1.32.0.1.M2

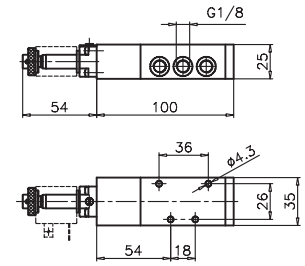

Weight 280 g  
Minimum working pressure 2,5 bar  
468/1.52.0.1.M2

**Solenoid - Differential**

Coding: 468/1.●.0.12.M2

Operational characteristics	
Fluid	Filtered air. No lubrication needed, if applied it shall be continuous
Max. working pressure (bar)	10
Temperature °C	-5 ... +50
Flow rate at 6 bar with Δp=1 (NI/min)	540
Orifice size (mm)	6
Working ports size	G 1/8"

TYPE	
●	32 = 3 ways, 2 positions
●	52 = 5 ways, 2 positions

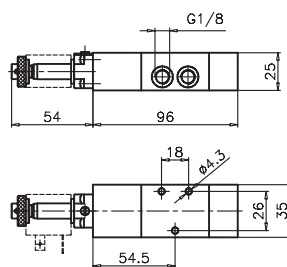
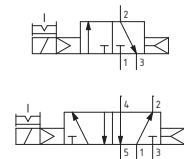

Weight 280 g  
Minimum working pressure 2,5 bar  
468/1.32.0.12.M2

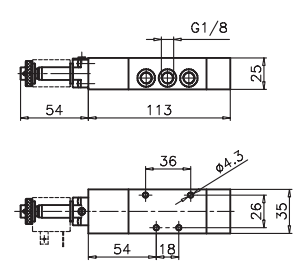

Weight 320 g  
Minimum working pressure 2,5 bar  
468/1.52.0.12.M2

**Solenoid - Solenoid**

Coding: 468/1.1.0.0.M2

**Operational characteristics**

Fluid	Filtered air. No lubrication needed, if applied it shall be continuous
Max. working pressure (bar)	10
Temperature °C	-5 ... +50
Flow rate at 6 bar with Δp=1 (NI/min)	540
Orifice size (mm)	6
Working ports size	G 1/8"

TYPE
1 32 = 3 ways, 2 positions
52 = 5 ways, 2 positions

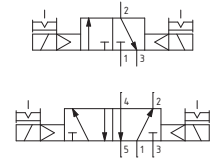

1 AIR DISTRIBUTION

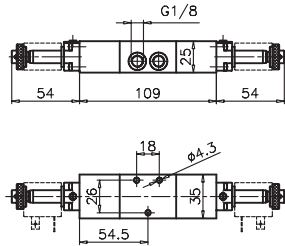

Weight 370 g  
Minimum working pressure 2 bar  
468/1.32.0.0.M2

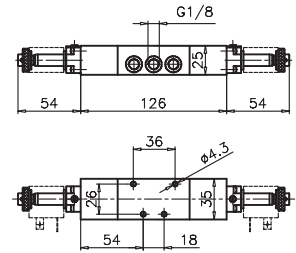

Weight 410 g  
Minimum working pressure 2 bar  
468/1.52.0.0.M2

**Solenoid - Solenoid - 5/3**

Coding: 468/1.53.0.0.M2

**Operational characteristics**

Fluid	Filtered air. No lubrication needed, if applied it shall be continuous
Max. working pressure (bar)	10
Temperature °C	-5 ... +50
Flow rate at 6 bar with Δp=1 (NI/min)	410
Orifice size (mm)	6
Working ports size	G 1/8"

FUNCTION
F 31 = Closed centres
32 = Open centres
33 = Pressured centres

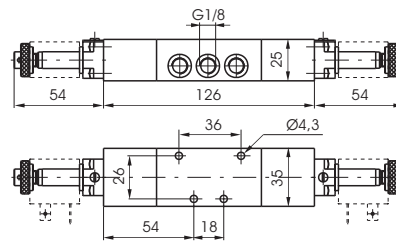

Weight 420 g  
Minimum working pressure 3 bar

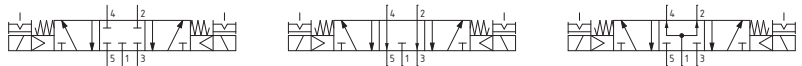

### Solenoid - Spring

Coding: 488.0.0.1.V

Operational characteristics	
Fluid	Filtered air. No lubrication needed, if applied it shall be continuous
Max. working pressure (bar)	10
Temperature °C	-5 ... +50
Flow rate at 6 bar with $\Delta p=1$ (NI/min)	620
Orifice size (mm)	6
Working ports size	G 1/8"
Response time according to ISO 12238, activation time (ms)	20,3 (3 ways) 22,5 (5 ways)
Response time according to ISO 12238, deactivation time (ms)	44,5 (3 ways) 47,0 (5 ways)

TYPE	
①	32 = 3 ways, 2 positions
	52 = 5 ways, 2 positions

VOLTAGE	
①	M9 = 24 V D.C.
	M11 = 24 V D.C.
	M56 = 24 V 50/60 Hz
	M57 = 110 V 50/60 Hz
	M58 = 230 V 50/60 Hz



Weight 220 g  
Minimum working pressure 2,5 bar

488.32.0.1.V

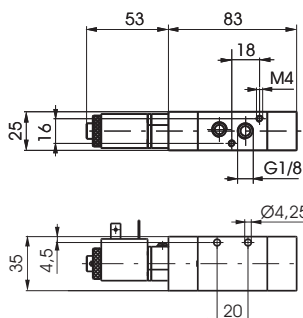
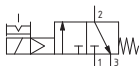

Weight 260 g  
Minimum working pressure 2,5 bar

488.52.0.1.V

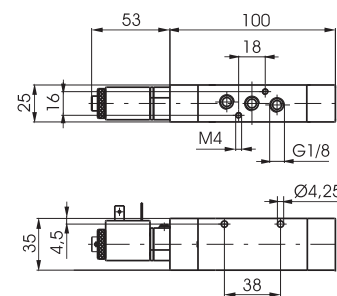
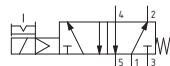

### Solenoid - Differential

Coding: 488.0.0.12.V

Operational characteristics	
Fluid	Filtered air. No lubrication needed, if applied it shall be continuous
Max. working pressure (bar)	10
Temperature °C	-5 ... +50
Flow rate at 6 bar with $\Delta p=1$ (NI/min)	620
Orifice size (mm)	6
Working ports size	G 1/8"
Response time according to ISO 12238, activation time (ms)	28,0 (3 ways) 28,3 (5 ways)
Response time according to ISO 12238, deactivation time (ms)	34,5 (3 ways) 35,5 (5 ways)

TYPE	
①	32 = 3 ways, 2 positions
	52 = 5 ways, 2 positions

VOLTAGE	
①	M9 = 24 V D.C.
	M11 = 24 V D.C.
	M56 = 24 V 50/60 Hz
	M57 = 110 V 50/60 Hz
	M58 = 230 V 50/60 Hz



Weight 220 g  
Minimum working pressure 2,5 bar

488.32.0.12.V

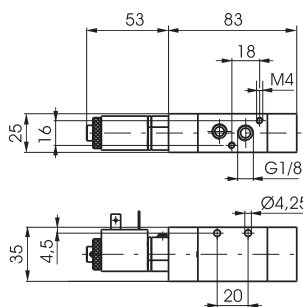
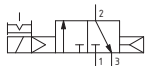

Weight 260 g  
Minimum working pressure 2,5 bar

488.52.0.12.V

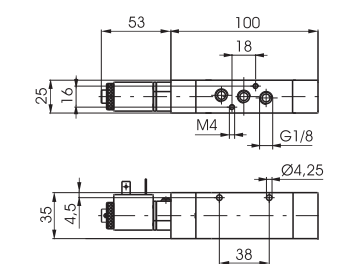
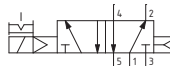

### Solenoid - Solenoid

Coding: 488.0.0.0.V

Operational characteristics	
Fluid	Filtered air. No lubrication needed, if applied it shall be continuous
Max. working pressure (bar)	10
Temperature °C	-5 ... +50
Flow rate at 6 bar with $\Delta p=1$ (NI/min)	410
Orifice size (mm)	6
Working ports size	G 1/8"
Response time according to ISO 12238, activation time (ms)	19,0 (3 ways) 18,2 (5 ways)
Response time according to ISO 12238, deactivation time (ms)	21,1 (3 ways) 18,5 (5 ways)

TYPE	
①	32 = 3 ways, 2 positions
	52 = 5 ways, 2 positions

VOLTAGE	
①	M9 = 24 V D.C.
	M11 = 24 V D.C.
	M56 = 24 V 50/60 Hz
	M57 = 110 V 50/60 Hz
	M58 = 230 V 50/60 Hz



Weight 320 g  
Minimum working pressure 2 bar

488.32.0.0.V

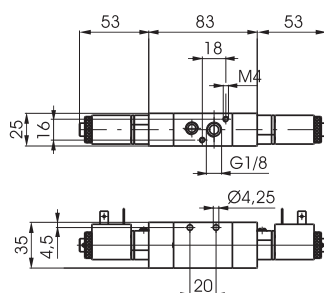
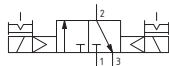

Weight 360 g  
Minimum working pressure 2 bar

488.52.0.0.V

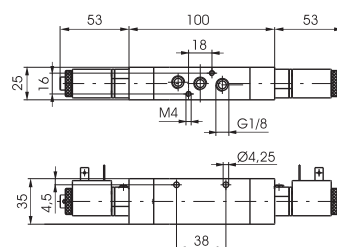
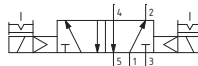

**Solenoid - Solenoid - 5/3**

Coding: 488.53.Ⓜ.0.0.Ⓜ

**Operational characteristics**

Fluid	Filtered air. No lubrication needed, if applied it shall be continuous
Max. working pressure (bar)	10
Temperature °C	-5 ... +50
Flow rate at 6 bar with Δp=1 (NI/min)	410
Orifice size (mm)	6
Working ports size	G 1/8"
Response time according to ISO 12238, activation time (ms)	23,0 (closed centres) 21,5 (open centres) 18,9 (pressured centres)
Response time according to ISO 12238, deactivation time (ms)	41,0 (closed centres) 38,0 (open centres) 40,2 (pressured centres)

FUNCTION
Ⓜ 31 = Closed centres
Ⓜ 32 = Open centres
Ⓜ 33 = Pressured centres

VOLTAGE
Ⓜ 9 = 24 V.D.C.
Ⓜ 11 = 24 V.D.C.
Ⓜ 56 = 24 V 50/60 Hz
Ⓜ 57 = 110 V 50/60 Hz
Ⓜ 58 = 230 V 50/60 Hz



Weight 400 g  
Minimum working pressure 3 bar

488.53.31.0.0.Ⓜ

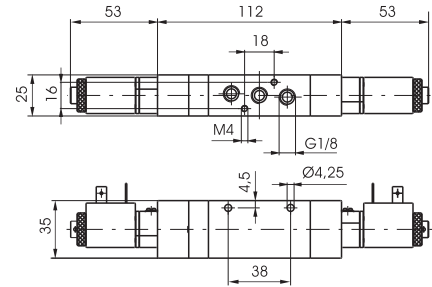
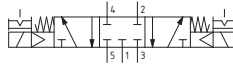

Weight 400 g  
Minimum working pressure 3 bar

488.53.32.0.0.Ⓜ

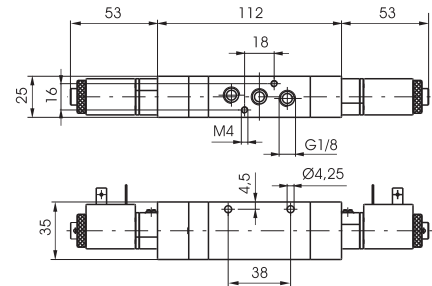
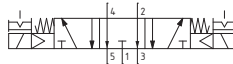

Weight 400 g  
Minimum working pressure 3 bar

488.53.33.0.0.Ⓜ

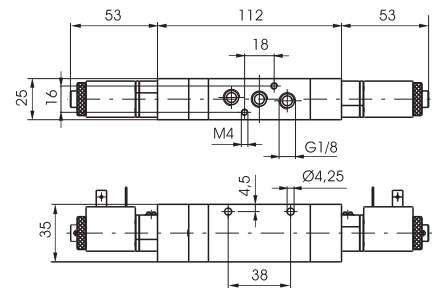
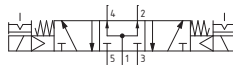

1 AIR DISTRIBUTION



**Solenoid - Spring**

Coding: 464.1.0.1.M2

**Operational characteristics**

Fluid	Filtered air. No lubrication needed, if applied it shall be continuous
Max. working pressure (bar)	10
Temperature °C	-5 ... +50
Flow rate at 6 bar with Δp=1 (NI/min)	1360
Orifice size (mm)	8
Working ports size	G 1/4"

TYPE	
1	32 = 3 ways, 2 positions 52 = 5 ways, 2 positions

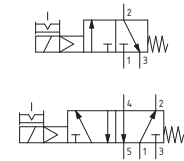

3/2 ways

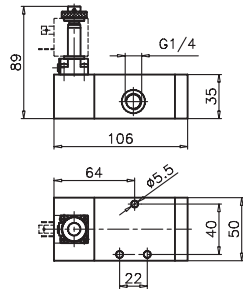

Weight 530 g  
Minimum working pressure 2,5 bar

464.32.0.1.M2

5/2 ways

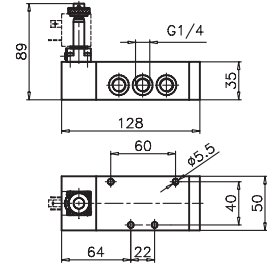

Weight 625 g  
Minimum working pressure 2,5 bar

464.52.0.1.M2

**Solenoid - Differential**

Coding: 464.1.0.12.M2

**Operational characteristics**

Fluid	Filtered air. No lubrication needed, if applied it shall be continuous
Max. working pressure (bar)	10
Temperature °C	-5 ... +50
Flow rate at 6 bar with Δp=1 (NI/min)	1360
Orifice size (mm)	8
Working ports size	G 1/4"

TYPE	
1	32 = 3 ways, 2 positions 52 = 5 ways, 2 positions

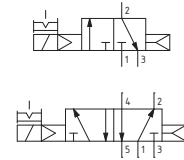

3/2 ways

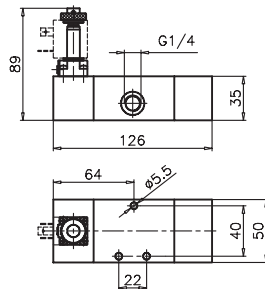

Weight 650 g  
Minimum working pressure 2,5 bar

464.32.0.12.M2

5/2 ways

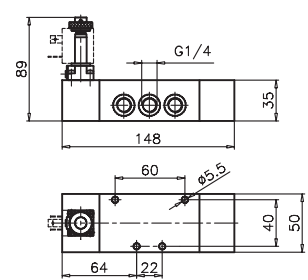

Weight 740 g  
Minimum working pressure 2,5 bar

464.52.0.12.M2

**Solenoid - Solenoid**

Coding: 464.1.0.0.M2

**Operational characteristics**

Fluid	Filtered air. No lubrication needed, if applied it shall be continuous
Max. working pressure (bar)	10
Temperature °C	-5 ... +50
Flow rate at 6 bar with Δp=1 (NI/min)	1360
Orifice size (mm)	8
Working ports size	G 1/4"

TYPE	
1	32 = 3 ways, 2 positions 52 = 5 ways, 2 positions

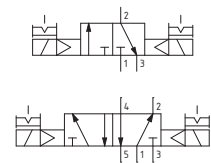

3/2 ways

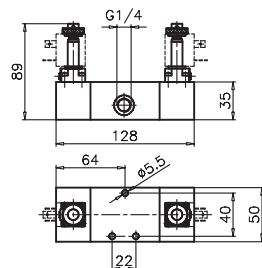

Weight 730 g  
Minimum working pressure 2 bar

464.32.0.0.M2

5/2 ways

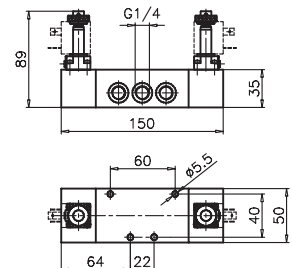

Weight 820 g  
Minimum working pressure 2 bar

464.52.0.0.M2

**Solenoid - Solenoid - 5/3**

Coding: 464.53.●.0.0.M2

Operational characteristics	
Fluid	Filtered air. No lubrication needed, if applied it shall be continuous
Max. working pressure (bar)	10
Temperature °C	-5 ... +50
Flow rate at 6 bar with Δp=1 (Nl/min)	1280
Orifice size (mm)	8
Working ports size	G 1/4"

FUNCTION	
●	31 = Closed centres
○	32 = Open centres
○	33 = Pressured centres

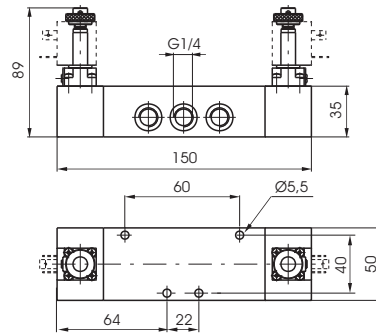

Weight 820 g  
Minimum working pressure 3 bar

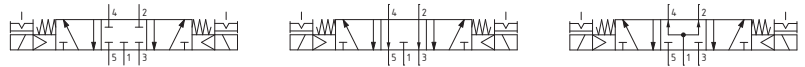

**Solenoid - Spring**

Coding: 464/1.1.0.1.M2

**Operational characteristics**

Fluid	Filtered air. No lubrication needed, if applied it shall be continuous
Max. working pressure (bar)	10
Temperature °C	-5 ... +50
Flow rate at 6 bar with Δp=1 (NI/min)	1360
Orifice size (mm)	8
Working ports size	G 1/4"

TYPE	
1 32 = 3 ways, 2 positions	
52 = 5 ways, 2 positions	

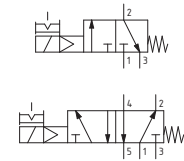

3/2 ways

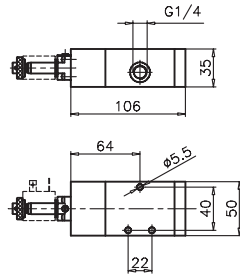

Weight 530 g  
Minimum working pressure 2,5 bar  
464/1.32.0.1.M2

5/2 ways

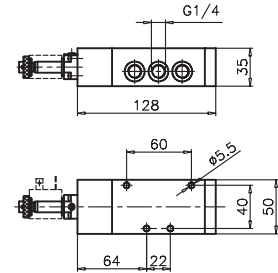

Weight 625 g  
Minimum working pressure 2,5 bar  
464/1.52.0.1.M2

**Solenoid - Differential**

Coding: 464/1.1.0.12.M2

**Operational characteristics**

Fluid	Filtered air. No lubrication needed, if applied it shall be continuous
Max. working pressure (bar)	10
Temperature °C	-5 ... +50
Flow rate at 6 bar with Δp=1 (NI/min)	1360
Orifice size (mm)	8
Working ports size	G 1/4"

TYPE	
1 32 = 3 ways, 2 positions	
52 = 5 ways, 2 positions	

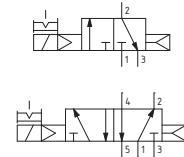

3/2 ways

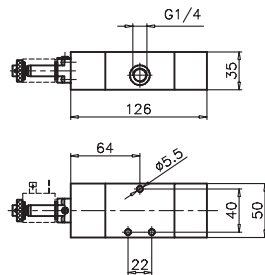

Weight 650 g  
Minimum working pressure 2,5 bar  
464/1.32.0.12.M2

5/2 ways

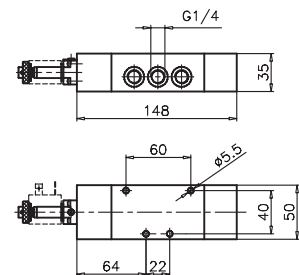

Weight 740 g  
Minimum working pressure 2,5 bar  
464/1.52.0.12.M2

**Solenoid - Solenoid**

Coding: 464/1.1.0.0.M2

**Operational characteristics**

Fluid	Filtered air. No lubrication needed, if applied it shall be continuous
Max. working pressure (bar)	10
Temperature °C	-5 ... +50
Flow rate at 6 bar with Δp=1 (NI/min)	1360
Orifice size (mm)	8
Working ports size	G 1/4"

TYPE	
1 32 = 3 ways, 2 positions	
52 = 5 ways, 2 positions	

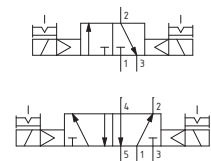

3/2 ways

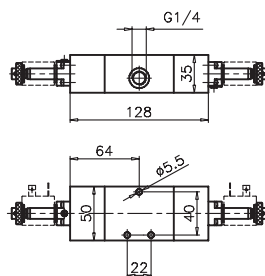

Weight 730 g  
Minimum working pressure 2 bar  
464/1.32.0.0.M2

5/2 ways

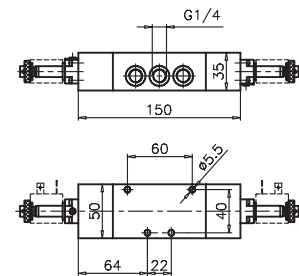

Weight 820 g  
Minimum working pressure 2 bar  
464/1.52.0.0.M2

**Solenoid - Solenoid - 5/3**

Coding: 464/1.53.Ⓢ.0.0.M2

Operational characteristics	
Fluid	Filtered air. No lubrication needed, if applied it shall be continuous
Max. working pressure (bar)	10
Temperature °C	-5 ... +50
Flow rate at 6 bar with Δp=1 (Nl/min)	1280
Orifice size (mm)	8
Working ports size	G 1/4"

FUNCTION	
Ⓢ1	Closed centres
Ⓢ2	Open centres
Ⓢ3	Pressured centres

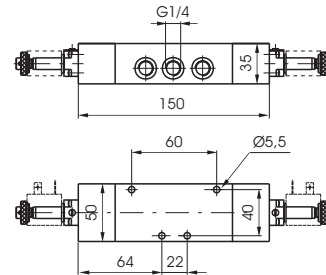

Weight 820 g  
Minimum working pressure 3 bar

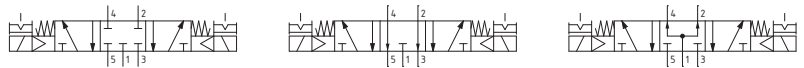

1  
AIR DISTRIBUTION

**Solenoid - Spring**

Coding: 452.Ⓡ.0.1.M2

Operational characteristics	
Fluid	Filtered air. No lubrication needed, if applied it shall be continuous
Max. working pressure (bar)	10
Temperature °C	-5 ... +50
Flow rate at 6 bar with Δp=1 (NI/min)	3500
Orifice size (mm)	15
Working ports size	G 1/2"

TYPE	
Ⓡ	32 = 3 ways, 2 positions
	52 = 5 ways, 2 positions



Weight 1152 g  
Minimum working pressure 2,5 bar

452.32.0.1.M2



Weight 1422 g  
Minimum working pressure 2,5 bar

452.52.0.1.M2

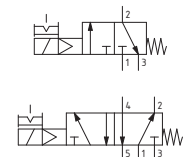
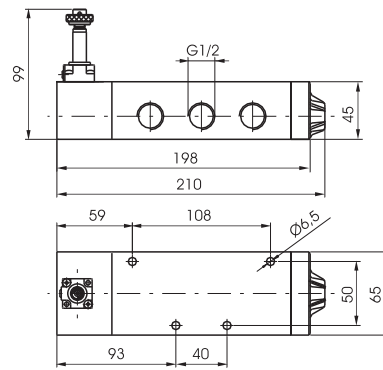
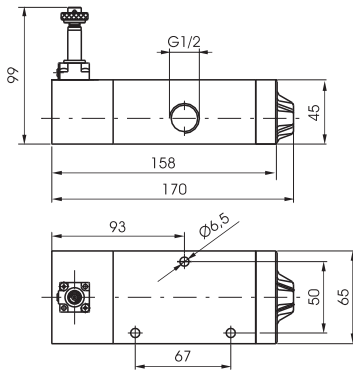

AIR DISTRIBUTION

1

**Solenoid - Differential**

Coding: 452.Ⓡ.0.12.M2

Operational characteristics	
Fluid	Filtered air. No lubrication needed, if applied it shall be continuous
Max. working pressure (bar)	10
Temperature °C	-5 ... +50
Flow rate at 6 bar with Δp=1 (NI/min)	3500
Orifice size (mm)	15
Working ports size	G 1/2"

TYPE	
Ⓡ	32 = 3 ways, 2 positions
	52 = 5 ways, 2 positions



Weight 1422 g  
Minimum working pressure 2,5 bar

452.32.0.12.M2



Weight 1692 g  
Minimum working pressure 2 bar

452.52.0.12.M2

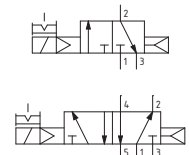
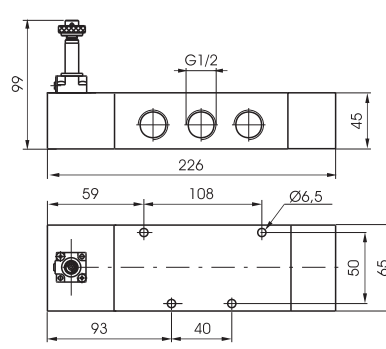
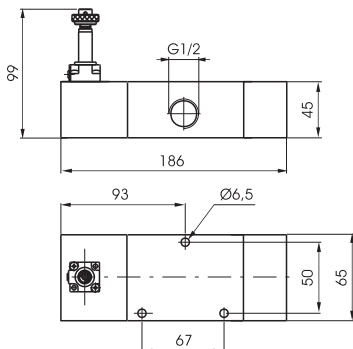

**Solenoid - Solenoid**

Coding: 452.1.0.0.M2

Operational characteristics	
Fluid	Filtered air. No lubrication needed, if applied it shall be continuous
Max. working pressure (bar)	10
Temperature °C	-5 ... +50
Flow rate at 6 bar with $\Delta p=1$ (NI/min)	3500
Orifice size (mm)	15
Working ports size	G 1/2"

TYPE	
1	32 = 3 ways, 2 positions
	52 = 5 ways, 2 positions



Weight 1474 g  
Minimum working pressure 2 bar

452.32.0.0.M2



Weight 1744 g  
Minimum working pressure 2 bar

452.52.0.0.M2

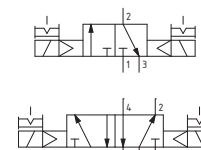
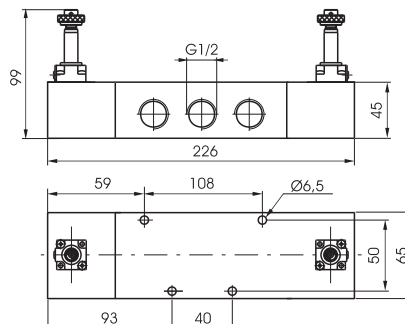
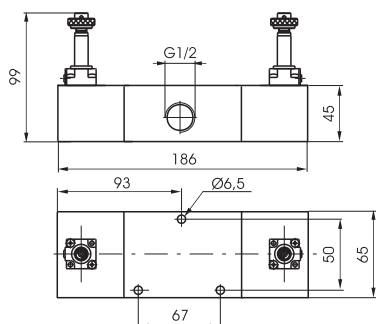

**Solenoid - Solenoid - 5/3**

Coding: 452.53.0.0.M2

Operational characteristics	
Fluid	Filtered air. No lubrication needed, if applied it shall be continuous
Max. working pressure (bar)	10
Temperature °C	-5 ... +50
Flow rate at 6 bar with $\Delta p=1$ (NI/min)	3500
Orifice size (mm)	15
Working ports size	G 1/2"

FUNCTION	
F	31 = Closed centres
	32 = Open centres
	33 = Pressured centres



Weight 1744 g  
Minimum working pressure 3 bar

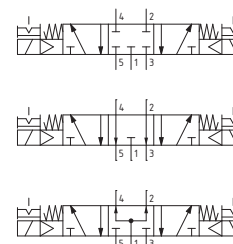
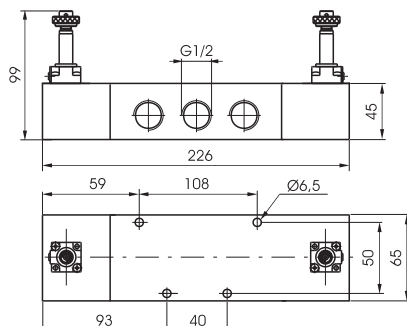

**Solenoid - Spring**

Coding: 452/1.1.0.1.M2

Operational characteristics	
Fluid	Filtered air. No lubrication needed, if applied it shall be continuous
Max. working pressure (bar)	10
Temperature °C	-5 ... +50
Flow rate at 6 bar with $\Delta p=1$ (NI/min)	3500
Orifice size (mm)	15
Working ports size	G 1/2"

TYPE	
1	32 = 3 ways, 2 positions
	52 = 5 ways, 2 positions



Weight 1330 g  
Minimum working pressure 2,5 bar

Weight 1600 g  
Minimum working pressure 2,5 bar

452/1.32.0.1.M2

452/1.52.0.1.M2

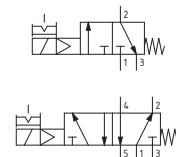
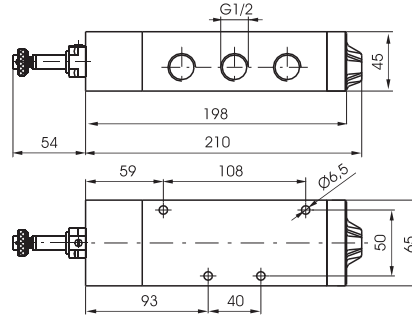
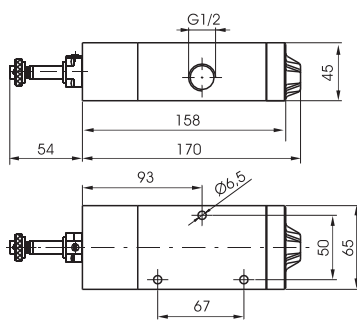

**Solenoid - Differential**

Coding: 452/1.1.0.12.M2

Operational characteristics	
Fluid	Filtered air. No lubrication needed, if applied it shall be continuous
Max. working pressure (bar)	10
Temperature °C	-5 ... +50
Flow rate at 6 bar with $\Delta p=1$ (NI/min)	3500
Orifice size (mm)	15
Working ports size	G 1/2"

TYPE	
1	32 = 3 ways, 2 positions
	52 = 5 ways, 2 positions



Weight 1600 g  
Minimum working pressure 2,5 bar

Weight 1870 g  
Minimum working pressure 2 bar

452/1.32.0.12.M2

452/1.52.0.12.M2

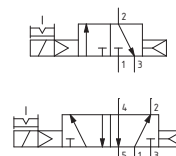
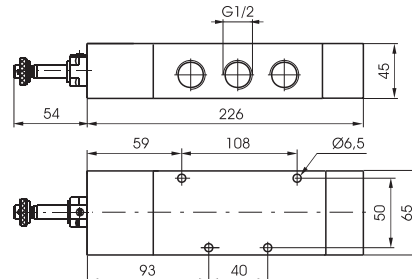
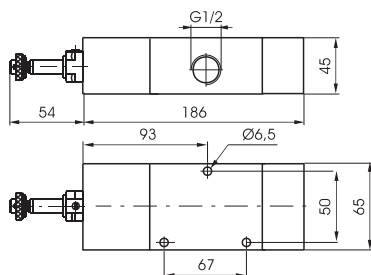

AIR DISTRIBUTION

1

**Solenoid - Solenoid**

Coding: 452/1.1.0.0.M2

Operational characteristics	
Fluid	Filtered air. No lubrication needed, if applied it shall be continuous
Max. working pressure (bar)	10
Temperature °C	-5 ... +50
Flow rate at 6 bar with $\Delta p=1$ (NI/min)	3500
Orifice size (mm)	15
Working ports size	G 1/2"

TYPE	
①	32 = 3 ways, 2 positions
	52 = 5 ways, 2 positions



Weight 1830 g  
Minimum working pressure 2 bar

452/1.32.0.0.M2



Weight 2100 g  
Minimum working pressure 2 bar

452/1.52.0.0.M2

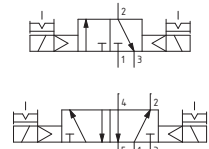
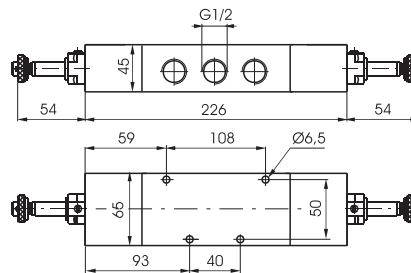
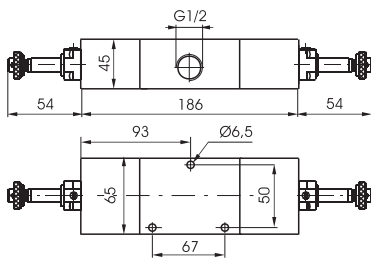

**Solenoid - Solenoid - 5/3**

Coding: 452/1.53.0.0.M2

Operational characteristics	
Fluid	Filtered air. No lubrication needed, if applied it shall be continuous
Max. working pressure (bar)	10
Temperature °C	-5 ... +50
Flow rate at 6 bar with $\Delta p=1$ (NI/min)	3500
Orifice size (mm)	15
Working ports size	G 1/2"

FUNCTION	
②	31 = Closed centres
	32 = Open centres
	33 = Pressured centres



Weight 2100 g  
Minimum working pressure 3 bar

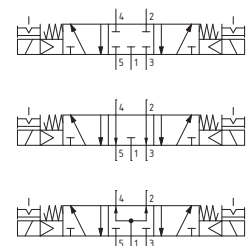
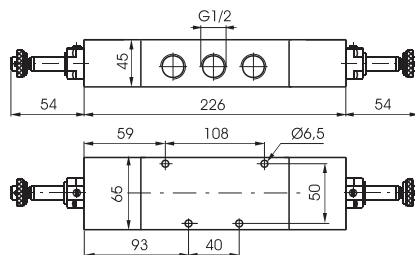

**Solenoid - Spring**

Coding: 412/2. **T**.0.1. **F**

**Operational characteristics**

Fluid	Filtered air. No lubrication needed, if applied it shall be continuous
Max. working pressure (bar)	10
Temperature °C	-5 ... +50
Flow rate at 6 bar with Δp=1 (NI/min)	3600
Orifice size (mm)	15
Working ports size	G 1/2"

TYPE	<b>T</b> 32 = 3 ways, 2 positions 52 = 5 ways, 2 positions
FUNCTION	<b>F</b> C.M2 = 3/2 ways Normally Closed A.M2 = 3/2 ways Normally Open M2 = 5/2 ways

3/2 ways

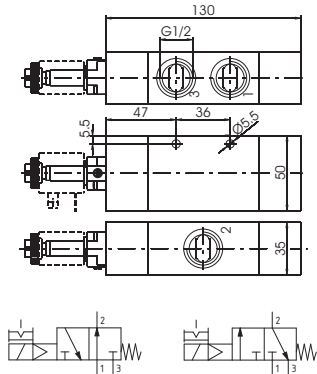

Weight 578 g  
Minimum working pressure 2,5 bar

412/2.32.0.1.C.M2

412/2.32.0.1.A.M2

5/2 ways

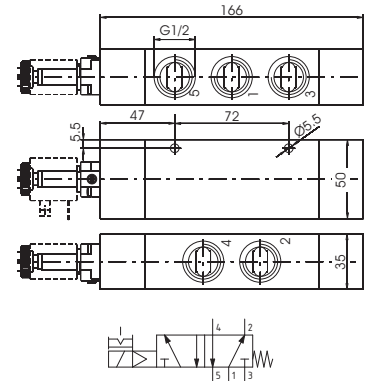

Weight 700 g  
Minimum working pressure 2,5 bar

412/2.52.0.1.M2

**Solenoid - Differential**

Coding: 412/2. **T**.0.12. **F**

**Operational characteristics**

Fluid	Filtered air. No lubrication needed, if applied it shall be continuous
Max. working pressure (bar)	10
Temperature °C	-5 ... +50
Flow rate at 6 bar with Δp=1 (NI/min)	3600
Orifice size (mm)	15
Working ports size	G 1/2"

TYPE	<b>T</b> 32 = 3 ways, 2 positions 52 = 5 ways, 2 positions
FUNCTION	<b>F</b> C.M2 = 3/2 ways Normally Closed A.M2 = 3/2 ways Normally Open M2 = 5/2 ways

3/2 ways

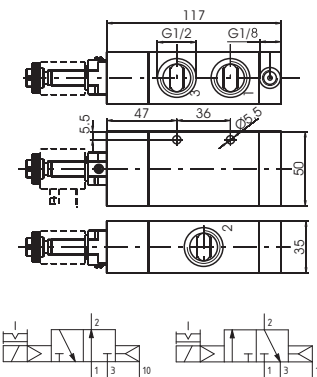

Weight 522 g  
Minimum working pressure 2,5 bar

412/2.32.0.12.C.M2

412/2.32.0.12.A.M2

5/2 ways

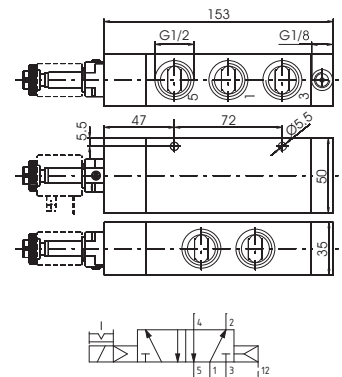

Weight 644 g  
Minimum working pressure 2,5 bar

412/2.52.0.12.M2

**Solenoid - Differential (Self feeding)**

Coding: 412/2. **T**.0.12/1. **F**

**Operational characteristics**

Fluid	Filtered air. No lubrication needed, if applied it shall be continuous
Max. working pressure (bar)	10
Temperature °C	-5 ... +50
Flow rate at 6 bar with Δp=1 (NI/min)	3600
Orifice size (mm)	15
Working ports size	G 1/2"

TYPE	<b>T</b> 32 = 3 ways, 2 positions 52 = 5 ways, 2 positions
FUNCTION	<b>F</b> C.M2 = 3/2 ways Normally Closed A.M2 = 3/2 ways Normally Open M2 = 5/2 ways

3/2 ways

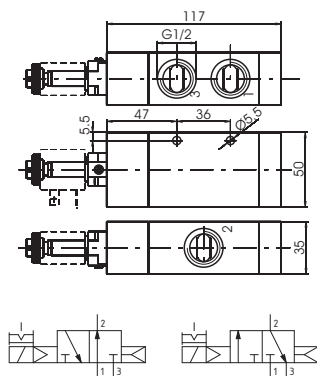

Weight 526 g  
Minimum working pressure 2,5 bar

412/2.32.0.12/1.C.M2

412/2.32.0.12/1.A.M2

5/2 ways

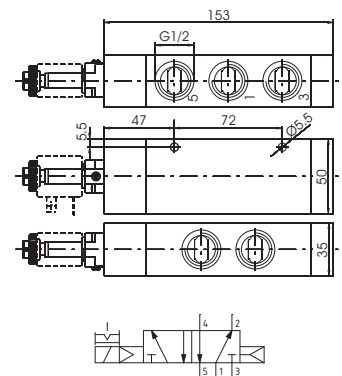

Weight 648 g  
Minimum working pressure 2,5 bar

412/2.52.0.12/1.M2

1 AIR DISTRIBUTION

**Solenoid - Solenoid**

Coding: 412/2.0.0.0.M2

Operational characteristics	
Fluid	Filtered air. No lubrication needed, if applied it shall be continuous
Max. working pressure (bar)	10
Temperature °C	-5 ... +50
Flow rate at 6 bar with Δp=1 (Nl/min)	3600
Orifice size (mm)	15
Working ports size	G 1/2"

TYPE	
<b>T</b>	32 = 3 ways, 2 positions
	52 = 5 ways, 2 positions

3/2 ways

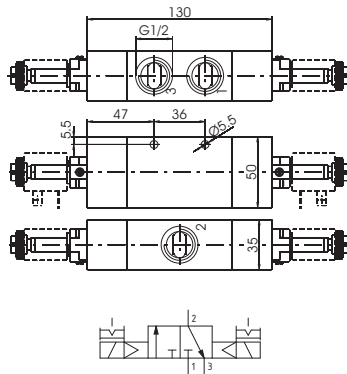

Weight 612 g  
Minimum working pressure 2 bar  
412/2.32.0.0.M2

5/2 ways

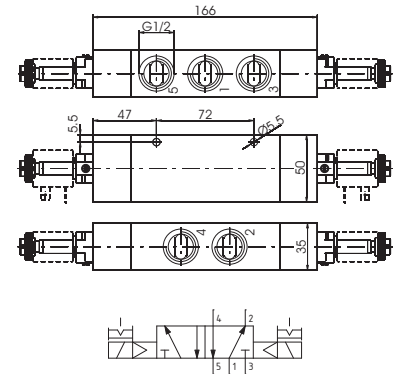

Weight 732 g  
Minimum working pressure 2 bar  
412/2.52.0.0.M2

**Solenoid - Solenoid - 5/3**

Coding: 412/2.53.0.0.M2

Operational characteristics	
Fluid	Filtered air. No lubrication needed, if applied it shall be continuous
Max. working pressure (bar)	10
Temperature °C	-5 ... +50
Flow rate at 6 bar with Δp=1 (Nl/min)	3300
Orifice size (mm)	15
Working ports size	G 1/2"

FUNCTION	
<b>F</b>	31 = Closed centres
	32 = Open centres
	33 = Pressured centres

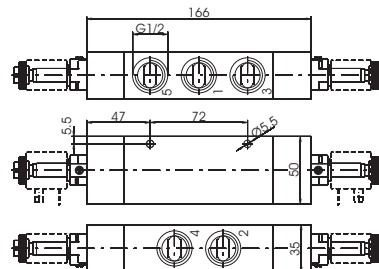

Weight 794 g  
Minimum working pressure 3 bar

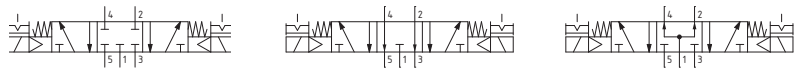

1  
AIR DISTRIBUTION

**Solenoid - Spring**

Coding: 411.Ⓡ.0.1.Ⓢ

**Operational characteristics**

Fluid	Filtered air. No lubrication needed, if applied it shall be continuous
Max. working pressure (bar)	10
Temperature °C	-5 ... +50
Flow rate at 6 bar with Δp=1 (NI/min)	6500
Orifice size (mm)	20
Working ports size	G 1"

TYPE	
Ⓡ	32 = 3 ways, 2 positions 52 = 5 ways, 2 positions
SOLENOID	
Ⓢ	SEE SOLENOID VALVES "S" TYPE, SERIES 300

AIR DISTRIBUTION

1

3/2 ways

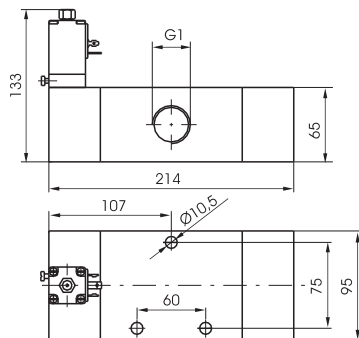

Weight 3400 g  
Minimum working pressure 2,5 bar

411.32.0.1.Ⓢ

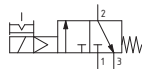

5/2 ways

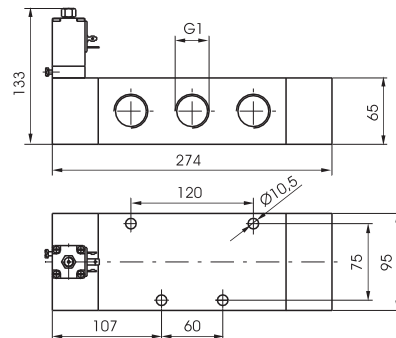

Weight 4300 g  
Minimum working pressure 2,5 bar

411.52.0.1.Ⓢ

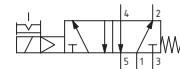

**Solenoid - Differential**

Coding: 411.Ⓡ.0.12.Ⓢ

**Operational characteristics**

Fluid	Filtered air. No lubrication needed, if applied it shall be continuous
Max. working pressure (bar)	10
Temperature °C	-5 ... +50
Flow rate at 6 bar with Δp=1 (NI/min)	6500
Orifice size (mm)	20
Working ports size	G 1"

TYPE	
Ⓡ	32 = 3 ways, 2 positions 52 = 5 ways, 2 positions
SOLENOID	
Ⓢ	SEE SOLENOID VALVES "S" TYPE, SERIES 300

3/2 ways

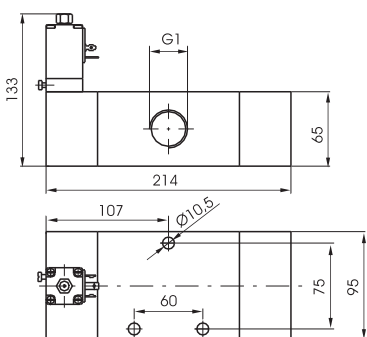

Weight 3400 g  
Minimum working pressure 2,5 bar

411.32.0.12.Ⓢ

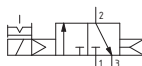

5/2 ways

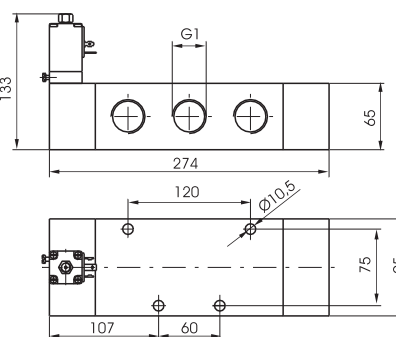

Weight 4300 g  
Minimum working pressure 2,5 bar

411.52.0.12.Ⓢ

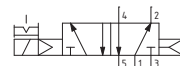

**Solenoid - Solenoid**

Coding: 411.1.0.0.S

Operational characteristics	
Fluid	Filtered air. No lubrication needed, if applied it shall be continuous
Max. working pressure (bar)	10
Temperature °C	-5 ... +50
Flow rate at 6 bar with $\Delta p=1$ (NI/min)	6500
Orifice size (mm)	20
Working ports size	G 1"

TYPE	
<b>T</b>	32 = 3 ways, 2 positions 52 = 5 ways, 2 positions
SOLENOID	
<b>S</b>	SEE SOLENOID VALVES "S" TYPE, SERIES 300

3/2 ways

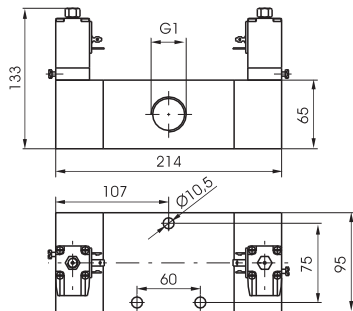

Weight 3700 g  
Minimum working pressure 2 bar

411.32.0.0.S

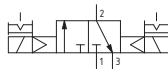

5/2 ways

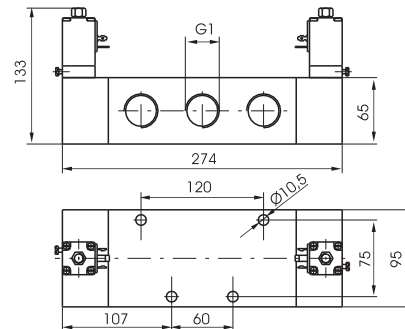

Weight 4600 g  
Minimum working pressure 2 bar

411.52.0.0.S

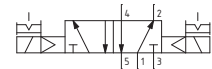

**Solenoid - Solenoid - 5/3**

Coding: 411.53.F.0.0.S

Operational characteristics	
Fluid	Filtered air. No lubrication needed, if applied it shall be continuous
Max. working pressure (bar)	10
Temperature °C	-5 ... +50
Flow rate at 6 bar with $\Delta p=1$ (NI/min)	6500
Orifice size (mm)	20
Working ports size	G 1"

FUNCTION	
<b>F</b>	31 = Closed centres 32 = Open centres 33 = Pressured centres
SOLENOID	
<b>S</b>	SEE SOLENOID VALVES "S" TYPE, SERIES 300

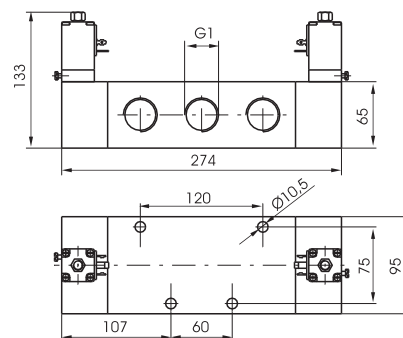

Weight 4700 g  
Minimum working pressure 3 bar

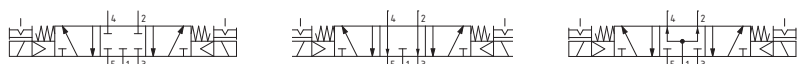

1  
AIR DISTRIBUTION